



Logic Convector Fire

Conventional Flue Coal Effect Convector Range



Instructions for Use, Installation and Servicing

For use in GB, IE (Great Britain and Republic of Ireland)

IMPORTANT

THIS PRODUCT HAS A NAKED FLAME. IT IS IMPORTANT TO ENSURE THAT ADEQUATE PRECAUTIONS ARE TAKEN TO ENSURE THAT NO OBJECTS COULD COME INTO CONTACT WITH THE NAKED FLAME. UNDER NO CIRCUMSTANCE SHOULD RUBBISH BE THROWN INTO OR BURNT ON THIS APPLIANCE.

PARTS OF THIS APPLIANCE WILL BECOME HOT DURING OPERATION; IT IS THEREFORE RECOMMENDED THAT A SUITABLE GUARD SHOULD BE USED FOR PROTECTION OF YOUNG CHILDREN, THE ELDERLY OR INFIRM.

These Instructions must be left with the appliance for future reference and for consultation when servicing the appliance. Please make the customer aware of the correct operation of the appliance before leaving these instructions with them.

The commissioning sheet found on Page 3 of this Instruction manual must be completed by the Installer prior to leaving the premises.

CONTENTS

LOGIC CONVECTOR - CONVENTIONAL FLUE

Covering the following models

GAS TYPE	LOGIC CONVECTOR		
	MANUAL CONTROL	REMOTE CONTROL	SLIDE CONTROL
Nat Gas	101-295	101-349	101-053
LPG	101-418	101-528	101-796

Appliance Commissioning Checklist	3
User Instructions	4
Installation Instructions	10
Technical Specifications	10
Site Requirements	12
Installation	16
Commissioning	22
Servicing Instructions	23
Fault Finding	23
How to replace parts	26
Basic spare parts list	32
Information Requirements	36
Service Record	38



To receive your Extended Warranty your Gazco appliance must have been purchased from our Expert Retailer Network and registered within one month of purchase or installation. Please note that all warranties are effective from the date of purchase. Any Gazco product purchased outside of our Extended Retailer Network, or not registered within the stated time will carry a standard 12 month warranty.

It is a condition of the Extended Warranty that the installation complies with the relevant Building Regulations and is carried out by a suitably trained and qualified individual (GasSafe in the UK or equivalent in other countries) with the certificate of installation and the Commissioning Report on Page 3 completed and retained by the end user.

Full terms and conditions are detailed in the Warranty Statement on the Gazco website www.gazco.com. In the event of any conflict of information the wording on the website shall prevail.

Important Note: Should any problems be experienced with your product, claims must first be submitted to the Expert Retailer where the appliance was purchased from who will offer immediate assistance or contact Gazco on your behalf.



It is a requirement of the Building Regulations 2010 that the installation of this appliance is notified to the Local Authority. It is the responsibility of the GasSafe registered installer to carry out this notification to the Local Authority via the GasSafe register Competent Persons Scheme in England and Wales (different rules apply in Scotland and Northern Ireland).

When the installation has been notified, GasSafe will send a Building Regulations Compliance Certificate to you containing details of the work completed. Please ensure that the person responsible for the installation of this appliance completes this notification and records it in the Appliance Commissioning Checklist on page 3.

IT IS YOUR RESPONSIBILITY TO COMPLY WITH THE BUILDING REGULATIONS AND BE ABLE TO PRODUCE THIS CERTIFICATE SHOULD IT BE REQUIRED IN THE FUTURE.

APPLIANCE COMMISSIONING CHECKLIST

To assist us in any guarantee claim please complete the following information:-

IMPORTANT NOTICE

Explain the operation of the appliance to the end user, hand the completed instructions to them for safe keeping, as the information will be required when making any guaranteed claims.

FLUE CHECK	PASS	FAIL
1. Flue Is correct for appliance		
2. Flue flow Test		
3. Spillage Test		
GAS CHECK	PASS	FAIL
1. Gas soundness & let by test		
2. Standing gas pressure	mb	
3. Appliance working pressure (on High Setting) NB All other gas appliances must be operating on full	mb	
4. Gas rate	m ³ /h	
5. Does Ventilation meet appliance requirements		
6. CO Alarm Fitted		
BUILDING CONTROL NOTIFICATION	YES	NO
1. Installer notified GasSafe/Local Authority of installation via Competent Persons Scheme?		

RETAILER AND INSTALLER INFORMATION

Retailer	Installation Company
.....
.....
Contact No.	Engineer
Date of Purchase	Contact No.
Model No.	GasSafe Reg No.
Serial No.	Date of Installation
Gas Type	

USER INSTRUCTIONS

WELCOME

Congratulations on purchasing your Logic fire, if installed correctly Gazco hope it will give you many years of warmth and pleasure for which it was designed.

The purpose of this manual is to familiarise you with your appliance, and give guidelines for its installation, operation and maintenance. If, after reading, you need further information, please do not hesitate to contact your Gazco retailer.

WARNING



In the event of a gas escape or if you can smell gas, please take the following steps:

- **Immediately turn off the gas supply at the meter/emergency control valve**
- **Extinguish all sources of ignition**
- **Do not smoke**
- **Do not operate any electrical light or power switches (On or Off)**
- **Ventilate the building(s) by opening doors and windows**
- **Ensure access to the premises can be made**

Please report the incident immediately to the National Gas Emergency Service Call Centre on 0800 111 999 (England, Scotland and Wales) , 0800 002 001 (N. Ireland) or in the case of LPG, the gas supplier whose details can be found on the bulk storage vessel or cylinder.

The gas supply must not be used until remedial action has been taken to correct the defect and the installation has been recommissioned by a competent person.

GENERAL

Installation and servicing must only be carried out by a competent person whose name appears on the GasSafe register. To ensure the engineer is registered with GasSafe they should possess an ID Card carrying the following logo:



In all correspondence, please quote the appliance type and serial number, which can be found on the data badge adjacent to the control knob.

Do not place curtains above the appliance:
You must have 300mm clearance between the appliance and any curtains at either side.

No furnishings or other objects should be placed within 1 metre of the front of the appliance.

If a shelf is fitted, a distance of 150mm above the appliance is required.

The decorative front will become hot during normal use and should be treated as a working surface. It is recommended that a suitable freguard be used for the protection of young children and the infirm.

This product is guaranteed for 5 years from the date of installation, as set out in the terms and conditions of sale between Gazco and your local Gazco retailer. Please consult with your local Gazco retailer if you have any questions. In all correspondence always quote the Model Number and Serial Number.

CO ALARMS

Building regulations require that whenever a new or replacement fixed gas burning appliance is installed in a dwelling, a carbon monoxide alarm complying with BS EN 50291-1 (latest edition) must be fitted in the same room as the appliance. Further guidance and recommendations on the installation of carbon monoxide alarms is available in BS EN 50292 (latest edition) and from manufacturers' instructions.

Provision of an alarm must not be considered a substitute for either installing the appliance correctly or ensuring regular servicing and maintenance of the appliance.



IMPORTANT: NEVER position a television or screen above this appliance.

OPERATING THE APPLIANCE

There are three types of control systems available for this appliance:

1. Manually Operated Control
2. Remote Control
3. Slide Control

Follow the relevant section for specific operation.

MANUAL CONTROL

Locate the control valve on the appliance. It has a single manual control:

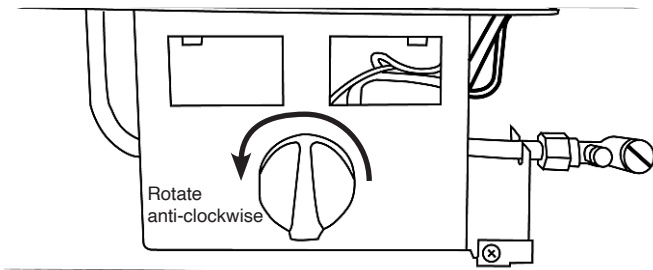

LIGHTING THE PILOT

Push the valve knob in and rotate anti-clockwise slowly until a click is heard. The pilot should now be lit.

Hold in for a further 10 seconds. When released the pilot should remain lit.

If the pilot does not remain lit, repeat until the operation is successful.

ADJUSTING THE FLAME HEIGHT

From the pilot position push the valve knob in slightly and rotate anti-clockwise until the first stop point is felt. This denotes the lowest setting.

Push the valve knob in slightly and rotate further in an anti-clockwise direction. The final stop point is the highest setting.

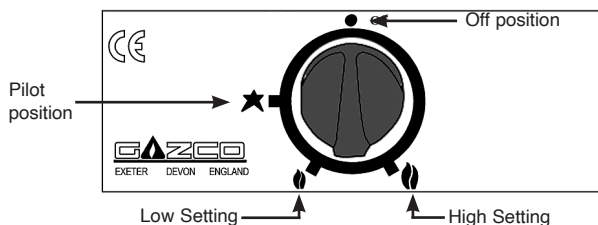

i **IMPORTANT: YELLOW FLAMES TYPICALLY APPEAR WHEN THE APPLIANCE HAS REACHED NORMAL OPERATING TEMPERATURE. THIS CAN TAKE UP TO 30 MINUTES.**

! **WARNING: IF THE APPLIANCE FAILS TO LIGHT OR BECOMES EXTINGUISHED IN USE, WAIT 3 MINUTES BEFORE ATTEMPTING TO RELIGHT.**

SWITCHING OFF THE APPLIANCE

To switch the appliance off turn the control knob clockwise until it is returned to the off position.

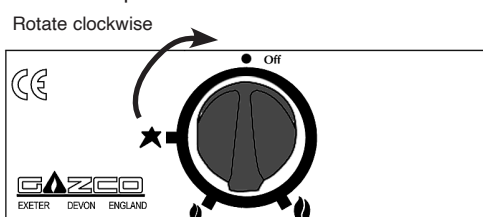

The knob should be upright.

REMOTE CONTROL

The pilot on Remote Control appliances must be lit manually from the valve unit before operation.

The control valve is at the foot on the right-hand side of the appliance. It has two controls, see Diagram 4:

1. The right-hand knob controls the pilot ignition.
2. The left-hand knob controls the main burner.

LIGHTING THE PILOT

To start the left-hand and right-hand control knobs must both point to off (●):

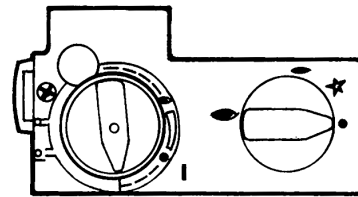

Press in the right-hand control knob and rotate anti-clockwise until a click is heard. Continue to press in. The knob points to the pilot (←).

The pilot is lit.

Keep the knob depressed for 10 seconds before releasing. The pilot remains lit.

Repeat the above steps if the pilot does not stay lit.

NOTE: If the pilot goes out, the Interlock system prevents you lighting again for a short period.

If, after repeating the above steps the pilot does not light, contact your Retailer or Installer.

Turn the right-hand control to point to main burner (↗). The appliance can now be controlled by the remote handset.

The Standard remote controls the appliance when:

- the pilot is lit.
- the right-hand control points to main burner (↗).

It regulates the temperature from low to high and back. It can also turn the main burner off leaving just the pilot burning and ready to operate.

To light the main burner:

To turn the appliance on, press the OFF and UP buttons simultaneously. Several short beeps sound. **The pilot and main burner ignite and the remote is now in Manual Mode.**

The remote's LED light flashes to show communication between the appliance's controls and the remote.

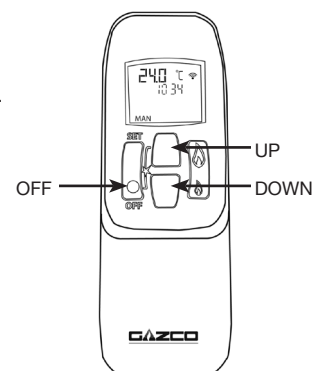



IMPORTANT: YELLOW FLAMES TYPICALLY APPEAR WHEN THE APPLIANCE HAS REACHED NORMAL OPERATING TEMPERATURE. THIS CAN TAKE UP TO 30 MINUTES.



WARNING: IF THE APPLIANCE FAILS TO LIGHT OR BECOMES EXTINGUISHED IN USE, WAIT 3 MINUTES BEFORE ATTEMPTING TO RELIGHT.

ADJUSTING THE FLAME HEIGHT

Increasing the Flame Height:

Press the UP button once to increase flame height one stage.
Press and hold the UP button to increase to maximum.

Decreasing the Flame Height:

Press the DOWN button once to decrease flame height one stage.
Press and hold the DOWN button to decrease to minimum.
At the lowest point the appliance goes to 'Standby Mode' (only Pilot lit).



NOTE: While pressing a button a symbol indicating transmission (📶) appears on the display. The receiver confirms transmission with a sound signal.

SWITCHING OFF THE APPLIANCE

THE REMOTE CONTROL CAN TURN THE MAIN BURNER OFF AND LEAVE THE PILOT BURNING AND READY TO OPERATE



To switch off the appliance completely (no pilot burning) return both control knobs to the off position (●).

Remote Control

To turn the main burner of the appliance off using the handset press and keep pressing the OFF button.

The main burner goes out leaving the pilot burning and ready to operate .

Controls on Appliance

Use the controls on the appliance to turn the appliance off by turning the left-hand control knob until it points to Off (●).
A click is heard and the main burner goes out leaving the pilot burning and ready to operate .

CAUTION: IN RARE INSTANCES, NOISES FROM SOURCES OUTSIDE THE REMOTE CAN OPERATE THE MAIN BURNER. IF THIS OCCURS, ALWAYS TURN THE CONTROL TO PILOT (●) OR OFF.

SLIDE CONTROL

This appliance is operated using the slide control on the top right hand side of the decorative front.

When the appliance is OFF the slide control will be at the highest point.

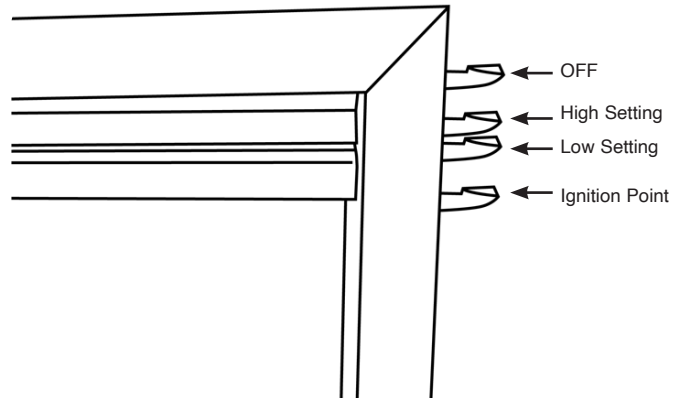

LIGHTING THE PILOT

Push the slide control down as far as possible to its lowest point, this is the ignition point.

Keep the slide control pressed down for 5 seconds to ensure the pilot is lit. Then release.

The appliance should light on its lowest setting.

When released the slide control automatically raises to a natural stop point.

Repeat the above steps if the appliance does not light.

If, after repeating the above steps the pilot does not light, contact your Retailer or Installer.

ADJUSTING THE FLAME HEIGHT

Increase the flame height and temperature by carefully moving the slide control up until the next stop point is felt, see Diagram 6. This denotes the highest setting.

Carefully move the slide control down to the lower stop point to return to the lowest setting.



IMPORTANT: YELLOW FLAMES TYPICALLY APPEAR WHEN THE APPLIANCE HAS REACHED NORMAL OPERATING TEMPERATURE. THIS CAN TAKE UP TO 30 MINUTES.



WARNING: IF THE APPLIANCE FAILS TO LIGHT OR BECOMES EXTINGUISHED IN USE, WAIT 3 MINUTES BEFORE ATTEMPTING TO RELIGHT.

SWITCHING OFF THE APPLIANCE

To turn the appliance off lift the slide control to its highest stop point. The pilot goes out.

CHANGING THE BATTERY (SLIDE CONTROL MODEL ONLY)

The appliance battery is located at the bottom left of the appliance behind the ash cover.

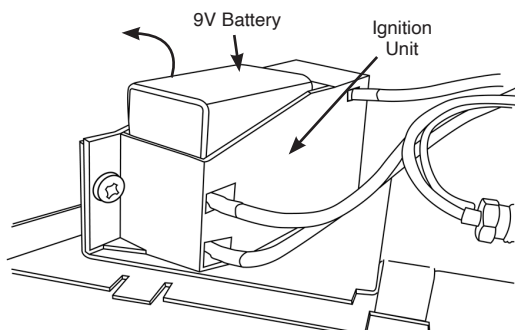

Remove the old battery and replace with a new high quality (Duracell or similar) 9V battery.

CLEANING THE APPLIANCE

Make sure the appliance and surrounds are cool before trying to clean.

Remove the ceramic coals and place on a dry clean surface.

Check the burner cover gasket for damage. Replace any damaged parts with genuine Gazco replacement parts, contact your Gazco retailer.

Carefully clean the burner and tray assembly using a vacuum cleaner with soft brush attachment, ensure all debris is removed from the burner ports.

WARNING: Take care when using a vacuum cleaner on the burner gasket as this is extremely delicate and may deteriorate after use.

Replace the ceramics.

ARRANGEMENT OF FUEL BED

ADVICE ON HANDLING AND DISPOSAL OF FIRE CERAMICS



The fuel effect of the log version of this appliance is made from Refractory Ceramic Fibre (RCF), a material which is commonly used for this application.

Protective clothing is not required when handling these articles, but we recommend you follow normal hygiene rules of not smoking, eating or drinking in the work area and always wash your hands before eating or drinking.

To ensure that the release of RCF fibres are kept to a minimum, during installation and servicing a HEPA filtered vacuum is recommended to remove any dust accumulated in and around the appliance before and after working on it. When servicing the appliance it is recommended that the replaced items are not broken up, but are sealed within heavy duty polythene bags and labelled as RCF waste.

RCF waste is classed as stable, non-reactive hazardous waste and may be disposed of at a licensed landfill site.

Excessive exposure to these materials may cause temporary irritation to eyes, skin and respiratory tract; wash hands thoroughly after handling the material.

NOTE: CERAMIC PARTS ARE FRAGILE. HANDLE WITH CARE.

ONLY USE THE CORRECT TYPE AND QUANTITY OF CERAMIC COMPONENTS. POINTS 5.1 TO 5.5 ARE COMMON TO ALL FUEL TYPES AND LAYOUTS.

ALWAYS FOLLOW THE FUEL BED LAYOUT AS STATED IN THESE INSTRUCTIONS. NEVER CHANGE THE LAYOUT FROM THAT SHOWN HERE.

Ensure the burner cover gasket is positioned on the burner skin ensuring the holes align with the ports.

Take care as the front left-hand hole is offset compared to the others, arrow A.

Remote Model shown

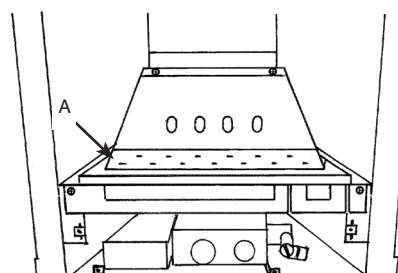

Position the flame baffle centrally on the tray and ensure the stepped lower edge engages against the rear edge of the burner skin.

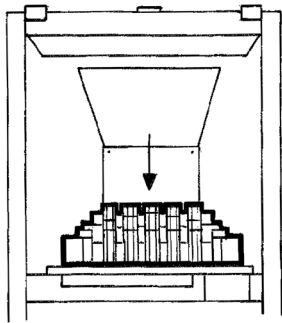

Place the rear panel against the rear of the box and slide the side panels on either side of the flame baffle. Ensure they locate in the brackets at the top of the firebox. DO NOT SLIDE THEM ALL THE WAY BACK.

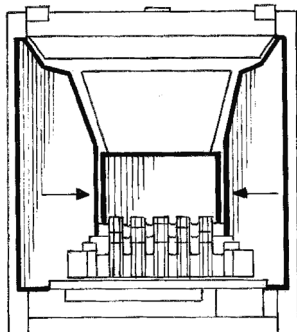

Locate the top panel on top of the rear and side panels. Finally push the sides fully towards the rear panel. This will retain the top panel.

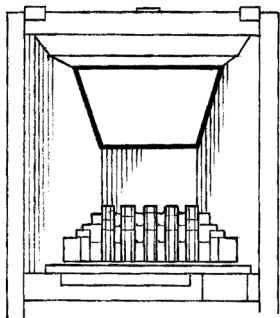

Place the front coal centrally in the channel at the front of the tray. The relationship between the front coal and flame baffle is shown.

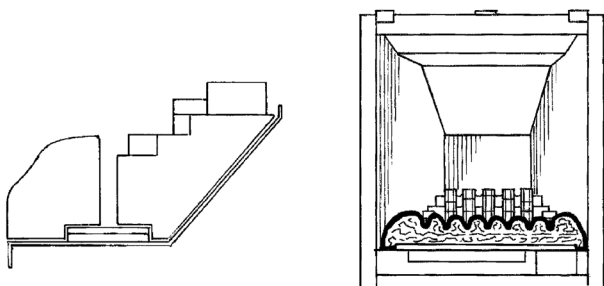

COAL LAYOUT

NOTE: THERE ARE TWO LARGE COALS IN A SEPARATE BAG INSIDE THE MAIN BAG FOR USE WITH A CURVED FRONT AND NOT FOR A FLAT FRONTED FRAME.

A) FRONT ROW COAL LAYOUT USING FLAT FIRE FRONTS

This first row marks the only difference in coal layout between the flat fronts and curved fronts. Place one large coal centrally on the front coal resting against the frame. Then place three small coals either side.

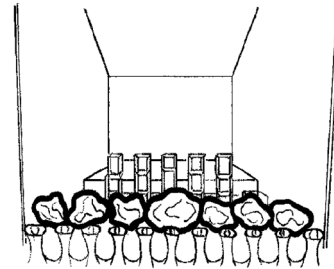

B) FRONT ROW COAL LAYOUT USING CURVED FIRE FRONTS

Place three large coals resting on top of the front coal and against the front of the frame, then place two small coals either side of the large ones.

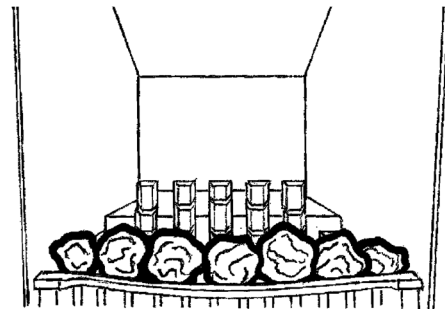

C) COAL LAYOUT CONTINUED FROM FRONT ROW

Place four large coals behind the first row and one small coal either end resting up against the side panels.

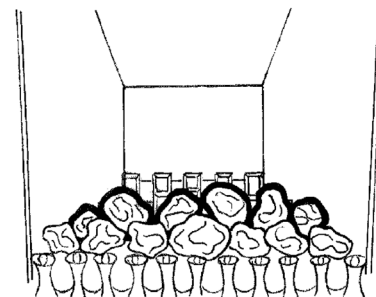

Place one small coal either side on top of the flame baffle in each

rear corner. Then place two large coals in between the two small coals. These coals should touch the rear panel.

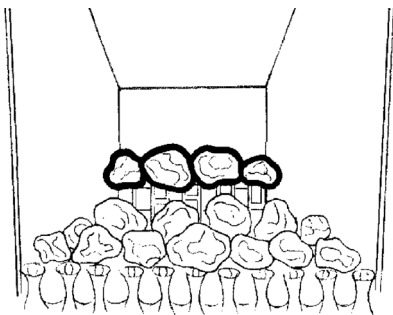

Finally place five large coals between the second and rear row of coals.

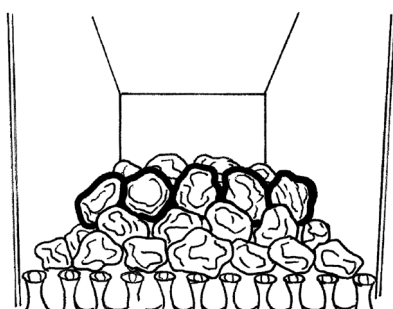

It is essential that gaps are left between the coals to maximise the performance of the appliance.

OXYGEN DEPLETION SENSOR

The appliance is fitted with an oxygen sensitive pilot system which acts to cut off the gas supply to the fire should the oxygen in the room fall below its normal level. If the fire is turned off by this device, it usually indicates that there is a problem with the flue system, and this should be inspected by a qualified engineer. **Do not attempt to use the fire until an engineer says it is safe to do so.**

This device is not a substitute for an independently mounted carbon monoxide detector.

FLAME FAILURE DEVICE

This is a safety feature incorporated on this appliance which automatically switches off the gas supply if the pilot goes out and fails to heat the thermocouple.

IF THIS OCCURS DO NOT ATTEMPT TO RELIGHT THE APPLIANCE FOR 3 MINUTES.

RUNNING IN

During initial use of a new Gazco appliance a strong odour will be encountered as various surface coatings become hot for the first time. Although these odours are harmless it is recommended that the appliance is operated on maximum for 4 to 8 hours in order to fully burn off these coatings. After this period the odours should then disappear.

If the odours persists, please contact your installer for advice.

During the first few hours of burning there may be discolouration of the flames. This will also disappear after a short period of use.

PILOT AREA WHITENING

Gas fire owners (not exclusive to Gazco) have reported issues of whitening around the pilot areas on their Conventional Flue glass fronted products. These white marks can also appear on glass or enamel panels inside the fire and on the inside of the glass which chemical analysis found to be Silicon Dioxide.

The cause of this is most likely a heat decomposition product of Siloxanes or similar compounds. Gazco can confirm that there are no Siloxane or similar products used in our conventionally flued fires and is therefore forming from sources external to the appliance. Siloxanes can be widely found in domestic cleaning products, cosmetics, scented room diffusers, candles and biomethane in the natural gas supply.

To reduce this problem, Gazco would recommend the removal of any products that could possibly contain Siloxanes from the room the fire is situated in.

SERVICING AND SUPPORT



To keep your appliance looking and performing at its best, it must be serviced annually. This service must be undertaken by a suitably qualified individual and your retailer can organise this for you. Alternatively, Gazco offer a manufacturers premium service with our friendly team of qualified engineers which can be booked at www.gazco.com/support.

In all correspondence always quote the Model number and the Serial number which may be found on the Commissioning Checklist (Page 3).

VENTILATION

Any purpose provided ventilation should be checked periodically to ensure that it is free from obstruction.

INSTALLATION DETAILS

Your installer should have completed the commissioning sheet at the front of this book. This records the essential installation details of the appliance. In all correspondence always quote the Model number and Serial number.

HOT SURFACES

Parts of this appliance become hot during normal use.

Regard all parts of the appliance as a working surface, except for the control access panel and the slider handle (slide control model only).

Provide a suitable fireguard to protect young children and the infirm.

INSTALLATION INSTRUCTIONS

TECHNICAL SPECIFICATION

Covering the following models:

GAS TYPE	LOGIC CONVECTOR		
	MANUAL CONTROL	REMOTE CONTROL	SLIDE CONTROL
Nat Gas	101-295	101-349	101-053
LPG	101-418	101-528	101-796

MODEL		GAS CAT.	GAS TYPE	WORKING PRESSURE	AERATION	INJECTOR	GAS RATE M ³ /HR		INPUT KW (GROSS)		COUNTRY
							HIGH	LOW	HIGH	LOW	
LOGIC CONVECTOR	Manual	I _{2H}	Natural (G20)	20mb	6 x 15	400	0.64	0.29	6.7	3.0	GB, IE
	Remote						0.64	0.29	6.7	3.0	
	Slide						0.628	0.29	6.6	3.0	
LOGIC CONVECTOR	Manual	I ₃₊	Butane (G30)	29mb	6 x 15 rear 23 x 15 front	180	0.192	0.086	6.7	3.0	GB, IE
			Propane (31)	37mb			0.252	0.113	6.7	3.0	
	Remote		Butane (G30)	29mb	6 x 15 rear 23 x 15 front	180	0.192	0.086	6.7	3.0	
			Propane (31)	37mb			0.252	0.113	6.7	3.0	
	Slide		Butane (G30)	29mb	6 x 15 rear 23 x 15 front	180	0.192	0.086	6.7	3.0	
			Propane (31)	37mb			0.252	0.113	6.7	3.0	
Net Efficiency - 68.5%											
NO_x CLASS 1											
Min Flue Size - 5" diameter											
Min Flue Size - pre cast - 90mm x 183mm (16,500mm² min)											
Min Flue Specification - T250/N2/O/D/1											
Gas Inlet - 8mm											
Weight - 19Kg											



The net efficiency of this appliance has been measured as specified in BS7977-1:2009 and the result after conversion to gross using the appropriate factor from Table E4 of SAP 10.2 is 61.72%. The test data has been certified by BSI Testing Services. The gross efficiency value may be used in the UK Government's Standard Assessment Procedure (SAP) for energy rating of dwellings.

COMPLETE FRONT OPTIONS

FRONT	MANUAL & REMOTE	SLIDE CONTROL
Winchester	8698MB	901-33

CONVECTOR FIREPLACES (CONVECTOR BOX ONLY)

FIREPLACE	BLACK	HIGHLIGHT POLISHED	POLISHED
Victorian Convector Manual & Remote	VCF03	VCF04SP	VCF04FP
Art Nouveau Manual & Remote	ACF03	ACF04	ACF04FP
Combination Convector Manual & Remote	4362	4363	-

FRAME & FRONT COMBINATIONS

BOX PROFIL		
FINISH	MANUAL & REMOTE	SLIDE
Matt Black	901-219	901-223
Polished Brass Effect	901-178	901-239
Polished Steel Effect	901-269	901-244
Brushed Steel Effect	901-344	901-251

FRONTS			
FINISH	ARTS FRONT	WAVE FRONT	CHARTWELL FRONT
Matt Black	901-425	901-024	901-159
Polished Brass Effect	901-530	901-061	901-164
Highlight Polished	901-296	901-092	901-185
Polished Chrome	901-476	901-083	901-170

DIMENSIONS

OVERALL EXTERNAL DIMENSIONS - SIDE VIEW

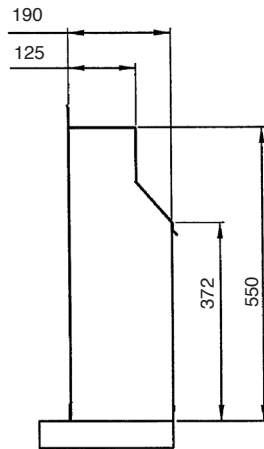

MINIMUM DEBRIS COLLECTION SPACE REQUIREMENTS (EXISTING MASONRY CHIMNEYS ONLY)

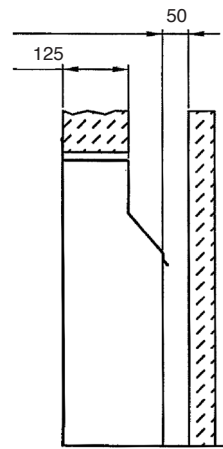

OVERALL EXTERNAL DIMENSIONS PLAN VIEW

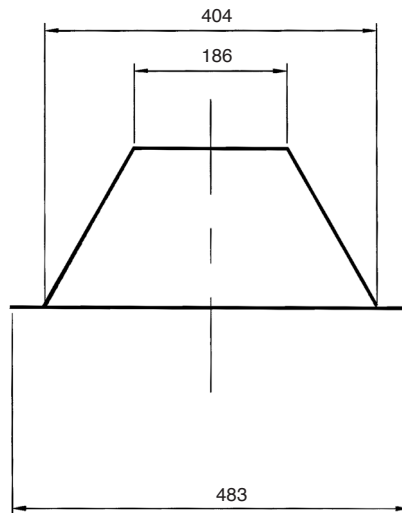

SITE REQUIREMENTS

FLUE AND CHIMNEY REQUIREMENTS

WHEN INSTALLING A FLUE SYSTEM PLEASE REFER TO THE MANUFACTURERS INSTRUCTIONS.

The European chimney standards now describe chimneys and flues by their temperature, pressure and resistance to corrosion, condensation and fire. To identify the correct flue system, the minimum flue specification is shown in the Technical Specification. Existing chimneys are not covered by this system.

The chimney or flue system must comply with the rules in force, and must be a minimum of 125mm (5") in diameter.

EXISTING BRICK CHIMNEY

A 127mm liner must be used if fitting the appliance into an existing brick built chimney. Larger lined flues can work, but in some instances could cause

cold start flue problems resulting in nuisance shutdown. Lined flues above 175mm are not recommended.

Suitable systems are:

- a) Flexible liner which must be continuous from the appliance spigot to the roof terminal.
- b) Gazco Linerless kit.

UNDER NO CIRCUMSTANCES MUST THE LINERLESS KIT BE USED WITH ANY INSTALLATION OTHER THAN AN EXISTING MASONRY CHIMNEY WHICH HAS A MINIMUM DIAMETER OF 178mm. THE CHIMNEY MUST BE SOUND AND CLEAN. IF PREVIOUSLY USED FOR SOLID FUEL, IT MUST BE SWEEPED PRIOR TO PROCEEDING WITH THE INSTALLATION.

NOTE: If the Linerless kit is to be used, due care should be taken to prevent condensation forming in the chimney. Do not fit the Linerless Kit if the chimney is taller than 10 metres (external wall) or 12 metres (internal wall).

The minimum flue height for the appliance must be 3 metres. Any horizontal flue run from the rear outlet must not exceed 100mm from the back of the appliance.

A minimum of 100mm vertical flue above the top outlet spigot should be provided before any offset of the flue.

The chimney or flue must be free from any obstruction. Any damper plates must be removed or secured in the fully open position, and no restrictor plates fitted.

The chimney must be swept prior to the installation, but it need not be swept if it can be seen the chimney is clean and unobstructed throughout its entire length.

PRE-CAST FLUES

Pre-cast flues must conform to BS1289: 1986. The cross sectional area of the flue must be 16500mm² with a minimum dimension of 90mm.

*When fitting the appliance to a pre cast flue, the total minimum depth of fire opening necessary is (D) 215mm. This allows a 25mm space behind the appliance for debris, required on this type of flue system. This is achieved either by using = (A) a 115mm deep starter block + (B) a 25mm plasterboard and sealed space + (C) 75mm Gazco spacer (part number 8315) with a marble slip or similar, inserted behind the spacer front flange, see Diagram 1.

Or the total depth can be achieved by using a deeper starter block, remedial building work to the front of the fireplace opening, and a marble slip or similar, or a combination of this.

NEVER PLASTER DIRECT TO THE FACE OF A PRECAST FLUE. USE ADHESIVE TO FIX THE PLASTERBOARD TO THE FACE OF THE FLUE AND FINALLY SKIM THE PLASTERBOARD.

- A = Minimum precast flue starter block depth (115mm).
- B = Plasterboard and adhesive seal all around fire opening.
- C = Gazco spacer (8315)
- D = Minimum total depth including 25mm for debris.

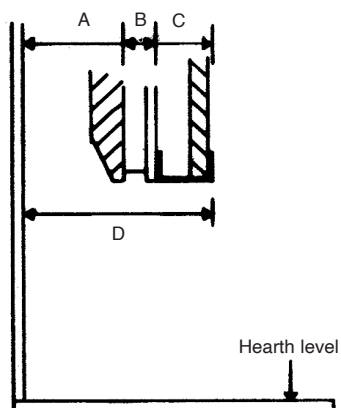

When fitting the Logic Convector fire and a Stovax Cast Iron Convector fireplace to a precast letter box flue with a standard starter block, the 8315 spacer kit will be required, together with an extra deep 142mm rebate surround.

If installing the Logic Convector fire in conjunction with a Stovax Combination Fireplace Convector, a 75mm deep stud-work chimney breast will need to be constructed to house the depth of the fireplace.

The appliance can also be fitted into a metal flue box with a 5" (125mm) diameter flexible liner. In this installation a 1" (25mm) rebated fire surround must be used. Refer to Diagram 2 for

dimensions.

* Class 1 flues. Chimneys over 9" (229mm) x 9" (229mm) must be lined.

A flue restrictor is provided which can be fitted when the flue is equal to or greater than 7" or when the flue pull is excessive.

Hot Box Restrictor - Fit in this orientation

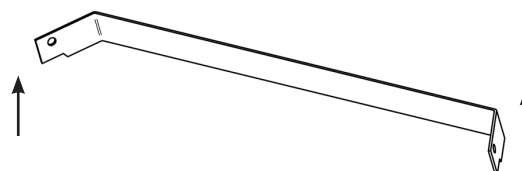

Convector Restrictor - Fit in this orientation

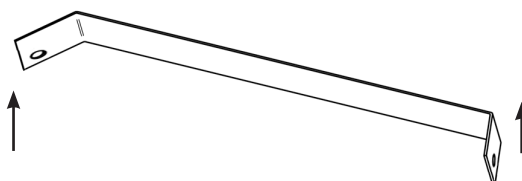

This is fitted through inside the appliance across the outlet at the top of the firebox with two screws provided, see Diagram 3.

Note: The Convector restrictor must be installed with the screw holes towards the bottom.

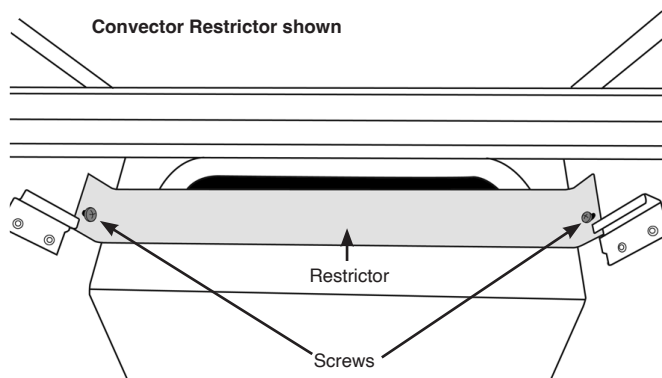

The minimum effective height of the flue or chimney must be 3m (10ft).

The chimney or flue must be free from any obstruction. Any damper plates should be removed or secured in the fully open position, and no restrictor plates should be fitted.

The chimney should be swept immediately prior to the installation of the appliance - unless it can be seen to be clean and unobstructed throughout its entire length.

Ensure that there is a smooth taper transition from the fireplace opening into the chimney or flue.

The flue pull should be checked prior to installation of the appliance. Apply a smoke pellet to the flue or chimney opening and ensure that the smoke is drawn into the opening. If there is not a definite flow, preheat the chimney for a few minutes and re-test the flow.

IF THERE IS STILL NO DEFINITE FLOW, THE CHIMNEY MAY REQUIRE ATTENTION - SEEK EXPERT ADVICE.

APPLIANCE LOCATION

NOTE: It is recommended you construct the back panel of the fireplace from natural materials cut into three or more sections to prevent cracking. Resin-based materials may not be suitable. This appliance is an effective heat producer and attention must be paid to the construction and finish of the fireplace.

These appliances must be hearth mounted into a non-combustible opening to National Standards. The minimum dimensions shall be as shown in Diagram.

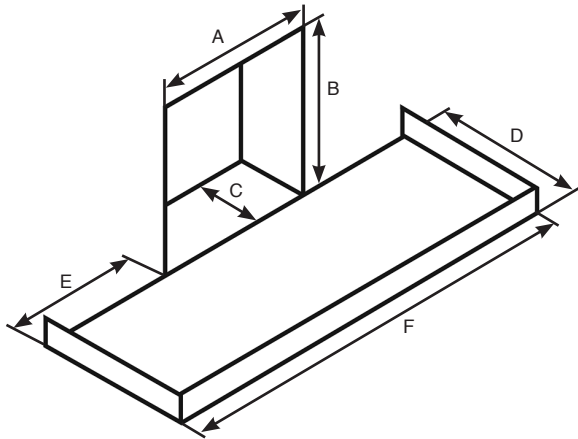

FLUE TYPE DIMENSION	BRICK BUILT CLASS 1	PRE FAB METAL BOX	PRE CAST FROM 1986
A	410	407	305
B	560	560	560
C	250	200	215
D	300	300	300
E	150	150	150
F	710	707	605

This appliance must stand on a non-combustible hearth that is at least 12mm thick and 50mm thick at least at the periphery.

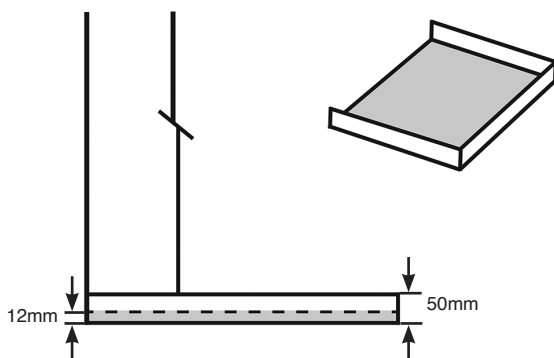

If the appliance is greater than 50mm above the floor, then no hearth is required, although due consideration should be given to how the heat may affect the floor material.

Ensure that no naked flame or incandescent part of the fire bed projects beyond the vertical plane of the fireplace opening.

The appliance must not be installed in any room that contains a bath or shower.

Ensure clearances to combustible materials.

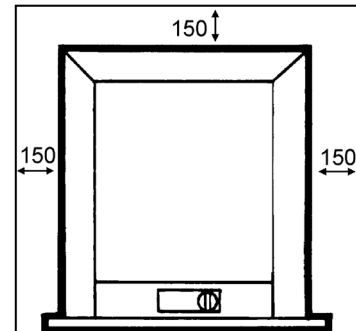

GAS SUPPLY

Before installation, ensure that the local distribution conditions (identification of gas and pressure) and the adjustment of the appliance are compatible.

Ensure that the gas supply is capable of delivering the required amount of gas, and is in accordance with the rules in force.

This appliance is supplied complete with a factory fitted isolation device incorporated into the inlet connection, no further isolation device is therefore required.

VENTILATION

It is important to ensure that any national ventilation requirements are taken into account during the installation of this appliance.

This appliance has a nominal input not exceeding 7.0kw and therefore does not normally require an additional permanent ventilation.

If, however, spillage is detected when commissioning the appliance, there may be insufficient natural ventilation and additional ventilation may be required.

For ventilation requirements in the Republic of Ireland, it will be necessary to refer to the relevant rules in force.

AIR VENTS MUST NOT BE RESTRICTED.

CO ALARMS

Building regulations require that whenever a new or replacement fixed gas burning appliance is installed in a dwelling, a carbon monoxide alarm complying with BS EN 50291-1 (latest edition) must be fitted in the same room as the appliance. Further guidance and recommendations on the installation of carbon monoxide alarms is available in BS EN 50292 (latest edition) and from manufacturers' instructions.

Provision of an alarm must not be considered a substitute for either installing the appliance correctly or ensuring regular servicing and maintenance of the appliance.

INSTALLATION

SAFETY PRECAUTIONS

For your own and other's safety, you must install this appliance according to local and national codes of practice. Failure to install the appliance correctly could lead to prosecution. **Read these instructions before installing and using this appliance.**

These instructions must be left intact with the user.

Do not attempt to burn rubbish on this appliance.

Keep all plastic bags away from young children.

Do not place any object on or near to the appliance and allow adequate clearance above the appliance.

IF THE APPLIANCE IS EXTINGUISHED OR GOES OUT IN USE, WAIT 3 MINUTES BEFORE ATTEMPTING TO RELIGHT THE APPLIANCE.

Do not use the appliance until an engineer says it is safe to do so.

i **IMPORTANT: REFER TO DATA BADGE AND TECHNICAL SPECIFICATION AT THE FRONT OF THE MANUAL TO ENSURE THE APPLIANCE IS CORRECTLY ADJUSTED FOR THE GAS TYPE AND CATEGORY APPLICABLE IN THE COUNTRY OF USE.**

UNPACKING

Remove the appliance from its packaging, and check that it is complete and undamaged.

Put the loose ceramic parts to one side so that they are not damaged during installation.

INSTALLATION OF THE GAS SUPPLY

For specific gas types and working pressures see **Technical Specifications, page 10.**

TO CHANGE FROM ONE GAS TYPE TO ANOTHER A COMPLETE ENGINE ASSEMBLY WILL BE REQUIRED. SEE SECTION 9 SERVICING INSTRUCTIONS.

Before installation, ensure that the local distribution conditions (identification of the type of gas and pressure) and the adjustment of the appliance are compatible. See Technical Specification on page 10.

Ensure that the gas supply is capable of delivering the required amount of gas, and is in accordance with the rules in force. Please refer to the technical specification for the correct working pressure for the gas used.

Soft copper tubing and soft soldered joints can be used but must not be closer than 50mm (2") to the underside of the burner.

An isolation device is provided with the appliance.

All supply gas pipes must be purged of any debris that may have entered, prior to connection to the appliance.

PREPARING THE APPLIANCE

MANUAL CONTROL

Remove the 5 burner retaining screws and withdraw the burner unit from its location.

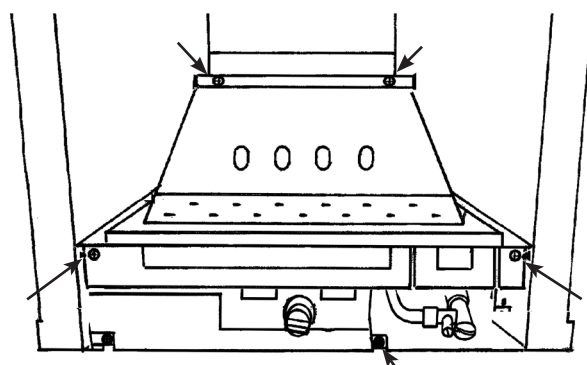

REMOTE CONTROL

Remove the 6 burner retaining screws and withdraw the burner unit from its location.

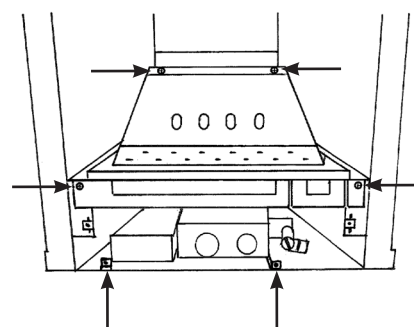

SLIDE CONTROL

Remove the 2 screws securing the front baffle to the burner unit, Arrow A. **Ensure the baffle is replaced during re-assembly.**

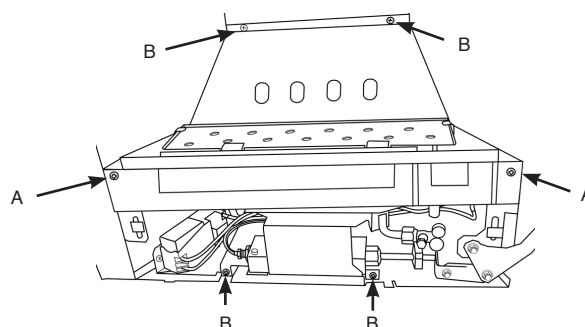

Remove the 4 screws securing the burner unit to the firebox, Arrow B.

Remove the M4 lock nut and spacer securing the slider arm to the appliance.

Ensure that the spacer is retained and replaced when the engine is reinstalled.

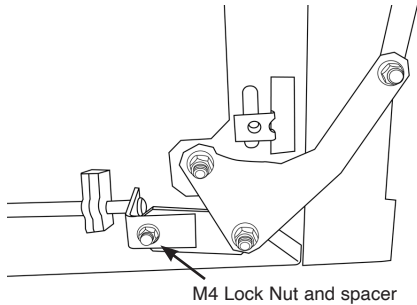

Withdraw the burner unit from its location.
Take care not to catch the slide mechanism.

ALL MODELS

Decide on the retention method. If cable fixings are to be used, remove the two knockout holes on the rear of the box, using a sharp hammer blow.

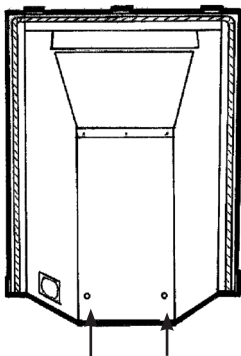

Remove the backing from the self-adhesive silicone sealing strip and apply to the rear flange of the firebox ensuring that it is positioned as close to the outer edge as is practically possible.

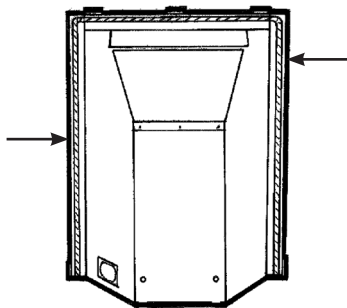

Gas pipe entry must come through the right hand side of the box. The rubber seal must be cut using a sharp knife to allow the isolating elbow to pass through it. Ensure the rubber is not damaged when doing this.

A means of isolation is provided with the appliance. This must be fitted to the supply pipe prior to installing the firebox.

INSTALLATION OF THE APPLIANCE

Ensure that the fireplace opening is in compliance with the requirements of Site Requirements then proceed as follows:

A) CABLE RETENTION METHOD

Mark the position of the 4 fixing holes on the rear of the fireplace opening and drill the holes using a No. 12 masonry drill bit. Insert the 4 fibre rawl plugs and screw the eyebolts in as far as possible leaving the eye horizontal.

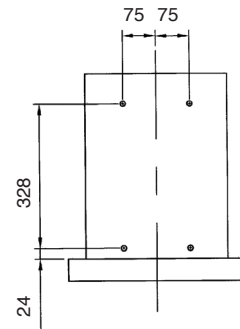

Pass the 2 cables through the holes in the bracket on the back of the firebox and pull taut so that the stop ends sit tightly against the top of the bracket.

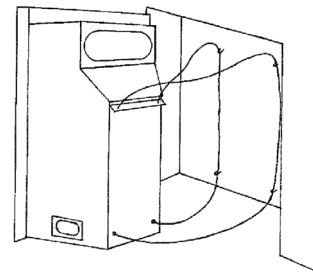

Pass the cables vertically through the 2 sets of eyebolts and thread the ends through the holes in the lower back of the firebox. Pass the gas supply pipe through the hole in the rubber seal and push the appliance into place.

Thread the cables through the tensioner bolts and push the threaded portions through the holes in the firebox so that the lock nut sits against the back wall (ensure that the nut is screwed fully up to the head of the tensioner to allow maximum adjustment).

Slide the locking nipples onto the cables, pull the cables taut and

tighten the locking screw. Adjust the lock nuts using a 10mm spanner until the silicone sealing strip forms a tight seal between the fireplace opening and the firebox flange.

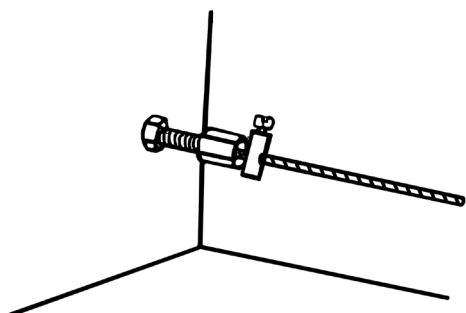

Coil up the surplus cable and locate in the back of the fire box.

NEVER SHORTEN THE CABLES, THEY WILL BE REQUIRED WHEN SERVICING THE APPLIANCE.

B) SCREW FIXING METHOD

Alternatively, this appliance can be secured back to the fire place opening using the screws and rawl plugs provided. Place the firebox centrally in the opening and mark the positions of the 4 fixing holes. Drill the holes and insert the 4 rawl plugs.

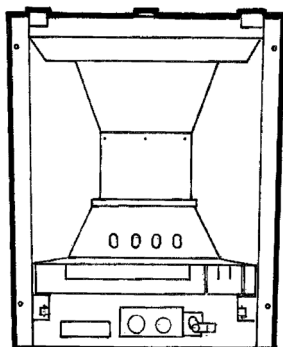

Offer the firebox into the opening and ensure that the gas supply pipe passes through the rubber seal.

Connect the gas supply to the inlet connection on the burner unit and tighten. It may be necessary to support the inlet connection with another spanner whilst tightening this joint.

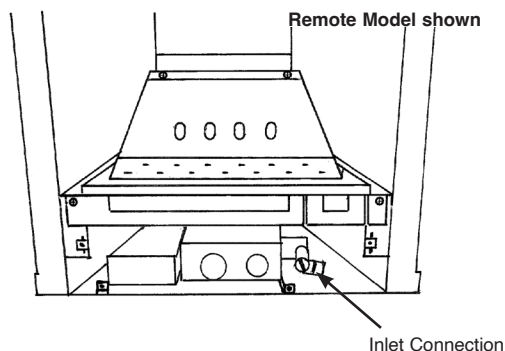

Carefully refit the burner assembly.

Slide Control Model only

Take care not to catch the slide mechanism.

Secure the 6 screws (Remote and Slide control models), 5 screws (Manual model).

SLIDE CONTROL MODEL ONLY

Refit the spacer and M4 lock nut to secure the slider mechanism.

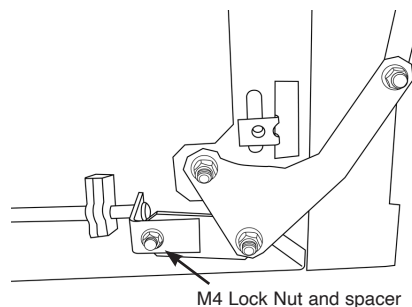

ALL MODELS

Turn on the gas supply to the appliance and check for leaks. Light the fire and check all joints on the appliance for leaks.

Remove the sealing screw from the inlet connection and connect a suitable "U" gauge manometer. Light the fire and turn to the maximum position, refer to the data badge and ensure that the running pressure is correct. If the pressure varies significantly from that on the data badge, this may indicate a supply problem and will require immediate attention.

Turn the appliance off, disconnect the "U" gauge and replace the sealing screw. Relight the appliance and check the sealing screw for leaks.

ARRANGEMENT OF FUEL BED

ADVICE ON HANDLING AND DISPOSAL OF FIRE CERAMICS



The fuel effect of the log version of this appliance is made from Refractory Ceramic Fibre (RCF), a material which is commonly used for this application.

Protective clothing is not required when handling these articles, but we recommend you follow normal hygiene rules of not smoking, eating or drinking in the work area and always wash your hands before eating or drinking.

To ensure that the release of RCF fibres are kept to a minimum, during installation and servicing a HEPA filtered vacuum is recommended to remove any dust accumulated in and around the appliance before and after working on it. When servicing the appliance it is recommended that the replaced items are not broken up, but are sealed within heavy duty polythene bags and labelled as RCF waste.

RCF waste is classed as stable, non-reactive hazardous waste and may be disposed of at a licensed landfill site.

Excessive exposure to these materials may cause temporary irritation to eyes, skin and respiratory tract; wash hands thoroughly after handling the material.

NOTE: CERAMIC PARTS ARE FRAGILE. HANDLE WITH CARE.

ONLY USE THE CORRECT TYPE AND QUANTITY OF CERAMIC COMPONENTS. POINTS 5.1 TO 5.5 ARE COMMON TO ALL FUEL TYPES AND LAYOUTS.

ALWAYS FOLLOW THE FUEL BED LAYOUT AS STATED IN THESE INSTRUCTIONS. NEVER CHANGE THE LAYOUT FROM THAT SHOWN HERE.

Ensure the burner cover gasket is positioned on the burner skin ensuring the holes align with the ports.

Take care as the front left-hand hole is offset compared to the others, arrow A.

Remote Model shown

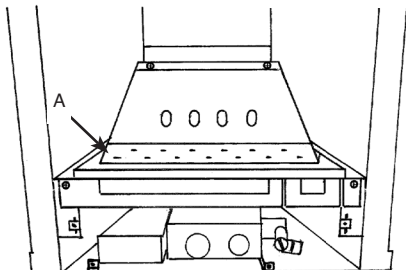

Position the flame baffle centrally on the tray and ensure the stepped lower edge engages against the rear edge of the burner skin.

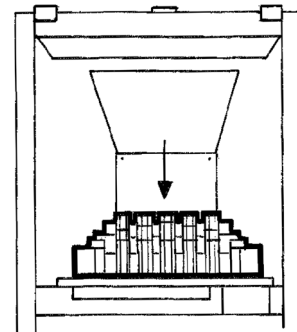

Place the rear panel against the rear of the box and slide the side panels on either side of the flame baffle. Ensure they locate in the brackets at the top of the firebox. **DO NOT SLIDE THEM ALL THE WAY BACK.**

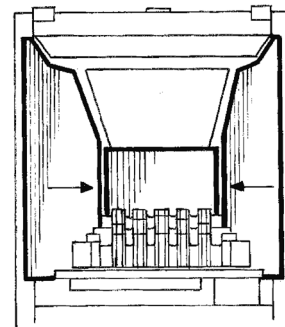

Locate the top panel on top of the rear and side panels. Finally push the sides fully towards the rear panel. This will retain the top panel.

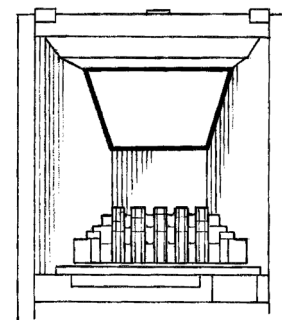

Place the front coal centrally in the channel at the front of the tray. The relationship between the front coal and flame baffle is shown.

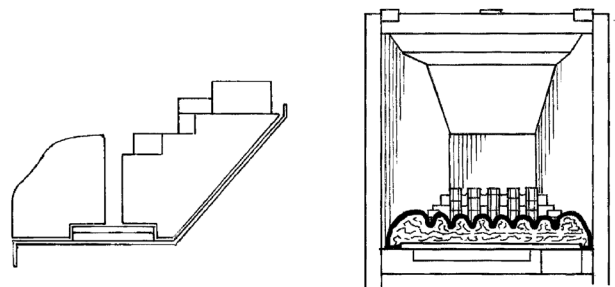

COAL LAYOUT

NOTE: THERE ARE TWO LARGE COALS IN A SEPARATE BAG INSIDE THE MAIN BAG FOR USE WITH A CURVED FRONT AND NOT FOR A FLAT FRONTED FRAME.

A) FRONT ROW COAL LAYOUT USING FLAT FIRE FRONTS

This first row marks the only difference in coal layout between the flat fronts and curved fronts. Place one large coal centrally on the front coal resting against the frame. Then place three small coals either side.

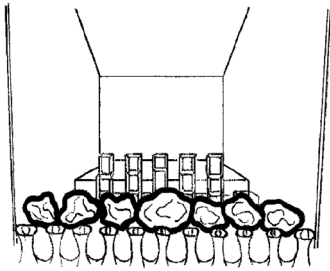

B) FRONT ROW COAL LAYOUT USING CURVED FIRE FRONTS

Place three large coals resting on top of the front coal and against the front of the frame, then place two small coals either side of the large ones.

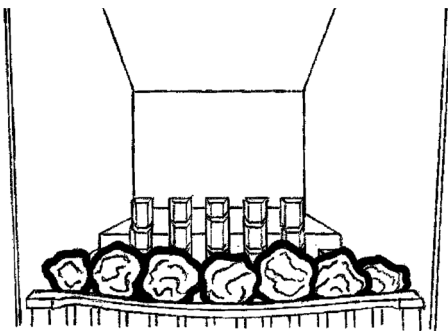

C) COAL LAYOUT CONTINUED FROM FRONT ROW

Place four large coals behind the first row and one small coal either end resting up against the side panels.

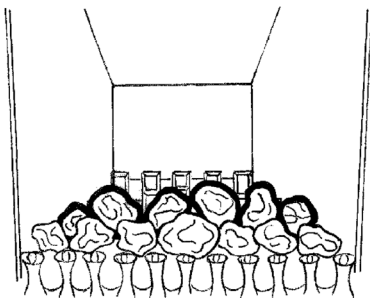

Place one small coal either side on top of the flame baffle in each

rear corner. Then place two large coals in between the two small coals. These coals should touch the rear panel.

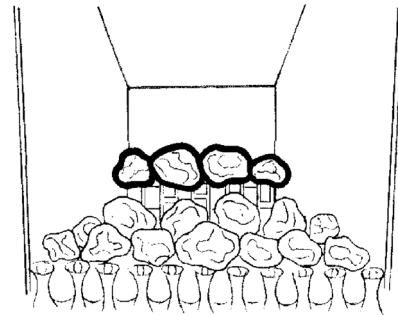

Finally place five large coals between the second and rear row of coals.

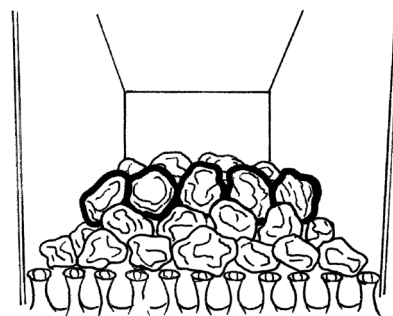

It is essential that gaps are left between the coals to maximise the performance of the appliance.

OPERATING THE APPLIANCE

The appliance is operated by thermostatic remote control.

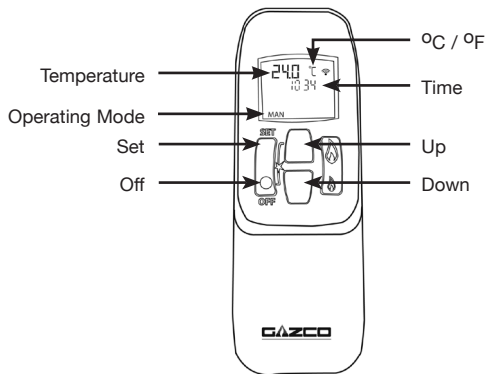

Turning the appliance On:

Your remote can control the gas appliance from pilot ignition through to shut down.

To turn the appliance on, press the OFF and UP buttons simultaneously. Several short beeps sound.

The pilot and main burner ignite and the remote is now in Manual Mode.

IMPORTANT: YELLOW FLAMES TYPICALLY APPEAR WHEN THE APPLIANCE HAS REACHED NORMAL OPERATING TEMPERATURE. THIS CAN TAKE UP TO 30 MINUTES.

WARNING: IF THE APPLIANCE FAILS TO LIGHT OR BECOMES EXTINGUISHED IN USE, WAIT 3 MINUTES BEFORE ATTEMPTING TO RELIGHT.

There are 3 different modes available for controlling and operating the appliance:

1. Manual Mode
2. Temp Mode (Automatic)
3. Timer Mode (Automatic)

In **MANUAL MODE** you can:

- Turn on the main burner using the UP button
- Regulate the flame from high to low and back
- Turn off the burner leaving just the pilot burning

In **TEMP MODE (Automatic)** you can:

- Set the room temperature so the thermostat in the remote automatically maintains that temperature

In **TIMER MODE (Automatic)** the appliance:

- Turns on and off according to the set time periods
- Automatically regulates the room temperature during the set periods

NOTE: When operating the appliance in TEMP or TIMER mode, the pilot remains lit and the appliance then automatically switches on at programmed times to bring the room to the set temperature, whether or not you are in the room. NEVER LEAVE ANY COMBUSTIBLE MATERIALS WITHIN 1 METRE OF THE FRONT OF THE APPLIANCE.

SWITCHING BETWEEN MODES

Press the SET button to change to Temperature (TEMP) Mode.

Press again to change to Timer Mode.

Keep pressing to run through all operating modes. These are:

- MAN
 - ● ON TEMP
 - ☺ OFF TEMP
 - TIMER
- and back to MAN

NOTE: MAN mode can also be reached by pressing either the UP or DOWN button.

MANUAL MODE

Press the OFF button and the UP button simultaneously.

Several clicks and audible beeps sound as the appliance begins the ignition process (up to 30 seconds).

Turning the appliance Off:

Press the OFF button to turn the appliance off.

FOR SAFETY, YOU MUST WAIT 30 SECONDS BEFORE LIGHTING THE APPLIANCE AGAIN.

Increasing the Flame Height:

Press the UP button once to increase flame height one stage. Press and hold the UP button to increase to maximum.

Decreasing the Flame Height:

Press the DOWN button once to decrease flame height one stage. Press and hold the DOWN button to decrease to minimum. At the lowest point the appliance goes to 'Standby Mode' (only Pilot lit).

NOTE: While pressing a button a symbol indicating transmission (📶) appears on the display. The receiver confirms transmission with a sound signal.

TEMP MODE (AUTOMATIC)

The display shows the current **room** temperature.

To increase or decrease the **appliance's** output:

Press the SET button to select either the ● ON TEMP or the ☺ OFF TEMP mode by briefly pressing the SET button.

Hold the SET button until the TEMP display flashes and then let go.

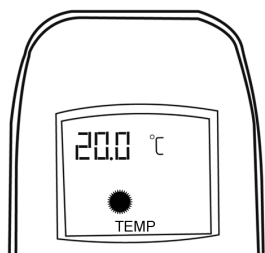

Set the desired ● ON temperature with the UP and DOWN arrows (minimum temperature 5°C and maximum 40°C, or 40°F and 99°F when Fahrenheit is the preferred option).

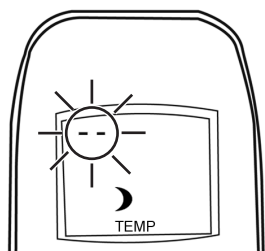

☾ OFF TEMP needs to be set to “— —”, otherwise the fire will turn on to heat if the room temperature drops.

Press the OFF button to stop the display flashing or wait to return to TEMP mode.

i **NOTE: If you set a temperature that is beneath the current room temperature, the appliance automatically switches to PILOT (standby).**

TIMER MODE (AUTOMATIC)

There are two programmable settings you can make over a 24 hour period: P1 and P2. These are normally used to provide an early morning and evening setting for each working week:

- P1 + ● = Start Timed Setting 1
- P1 + ☾ = End of Timed Setting 1
- P2 + ● = Start Timed Setting 2
- P2 + ☾ = End of Timed Setting 2

P1 - PROGRAM 1 FOR A TIMED SETTING

Press the SET button until the TIMER mode is displayed.

Hold the SET button. The display flashes the current time for P1. **While the time displayed is flashing you can alter the hours and minutes set.**

To set the time your appliance first lights, change P1 ● :

- Press the UP button to alter the hour
- Press the DOWN button to alter the minutes in 10 minute increments

Press SET again to move to the end setting for P1 ☾. This is the time your appliance first shuts down:

- Press the UP button to alter the hour
- Press the DOWN button to alter the minutes

P2 - PROGRAM 2 FOR A TIMED SETTING

Use the same steps as for P1, above, to change the setting for P2.

If you have already set P1 and want to alter the setting for P2 only:

- Press the SET button until TIMER mode is displayed
- Hold the SET button **until the display flashes the current time** for P1 ●
- Press the SET button once again to scroll past the settings for P1 ● and P1 ☾

With the time still flashing:

- Press the UP button to alter the hour
- Press the DOWN button to alter the minutes

Once all four times are set, press the OFF button or simply wait.

To view existing settings:

- Select Timer Mode
- Press and briefly hold the SET button until you see the start time for P1
- Repeat the above step for the start and end of each program

i **NOTE: If the room temperature exceeds the temperature set on the handset, the fire will not automatically turn on at the set time.**

LOW BATTERY

BATT is displayed on the remote when its batteries need replacement.

SETTING THE TIME

Simultaneously press the UP and DOWN buttons.

Press the UP button to set the hour and the DOWN button to set the minutes.

Press OFF to return to the manual mode or simply wait.

SETTING THE °C/24 HOUR OR °F/12 HOUR CLOCK

Press OFF and the DOWN arrow until the display changes from °C/24 hour clock to °F/12 hour clock and vice versa (Celcius shows the time in the 24 hour format and Fahrenheit shows the 12 hour).

i **If the remote is removed, lost or damaged, signals transmitted to the receiver cease. Your appliance will go to standby (pilot) mode after 6 hours.**

SUPPORT VIDEOS

For help with pairing and using your GV60 control system, please scan the QR code or visit www.stovax.tv/video/control-system-gazco-fire-stove



TROUBLESHOOTING



IMPORTANT: In the unlikely event that the handset fails to communicate correctly with the appliance it may be necessary to turn off the gas supply at the isolation valve until any problems can be resolved.

The gas meter and isolation valve can be located outside in a meter box, under the stairs, beneath the kitchen sink or in the garage. Whilst this list is not exhaustive, it is important to be able to identify the location of the valve in case of any gas emergency.

To turn off the gas supply, simply turn the handle so the lever is at 90 degrees to the upright gas pipe.

If you smell gas, open doors and windows and never operate any electrical switches. Immediately call the Gas Emergency Services on 0800 111 999.

COMMISSIONING

Close all windows and doors to the room.

Check all controls, and allow fire to burn on maximum for 5 minutes.

Test for spillage of flue products using a smoke match.

Pass the lighted smoke match along the top front edge just inside the opening or canopy.

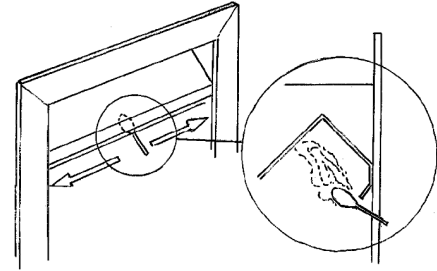

If the fire spills, run for a further 10 minutes and re-check.

Convector only

If the flue restrictor plate has been fitted to the fire this can be removed to assist flue flow if required.

If there are extractor fans in the room or adjacent rooms, the spillage test must be repeated with the extractors running on maximum.

IF SPILLAGE PERSISTS, DISCONNECT THE APPLIANCE AND SEEK EXPERT ADVICE.

Complete the Commissioning Checklist at the front of this manual covering:

- Flue checks
- Gas checks
- Log layout - flame picture

Upon completion of the commissioning and testing of the installation and correct operation of the appliance, the installer must instruct the user how to operate the appliance.

Guide the user through the User Instructions paying particular attention to:

- a) Regular servicing.
- b) Ventilation - point out the ventilation positions where applicable.
- c) Hot surfaces.

SERVICING INSTRUCTIONS

SERVICING REQUIREMENTS

This appliance must be serviced at least once a year by a competent person.

All tests must be serviced by best practice as described by the current GasSafe recommendations.

Before any tests are undertaken on the appliance, conduct a gas soundness test for the property to ensure that there are no gas leaks prior to starting work.

Before any tests are undertaken on the appliance it is also recommended to fully check the operation of the appliance.

Special checks

Clean any lint or fluff from the pilot - pay particular attention to the aeration hole in the side of the pilot.

Clean away any fluff or lint from under the burner

Check that the spark gap on the pilot is correct.

Correct any faults found during the initial tests and then recommission the appliance conducting the usual safety checks.

Advise the customer of any remedial action taken.

As part of the annual service, the space behind the firebox must be inspected for any debris, which may have fallen down the chimney.

Remove the gas fire from the firebox as detailed below.

Inspect the space behind the firebox for debris and the condition of the chimney, the flue flow test should be carried out now. Remove any debris and carry out any necessary remedial work.

FAULT FINDING CHARTS

IGNITION FUNCTIONAL CHECK 1

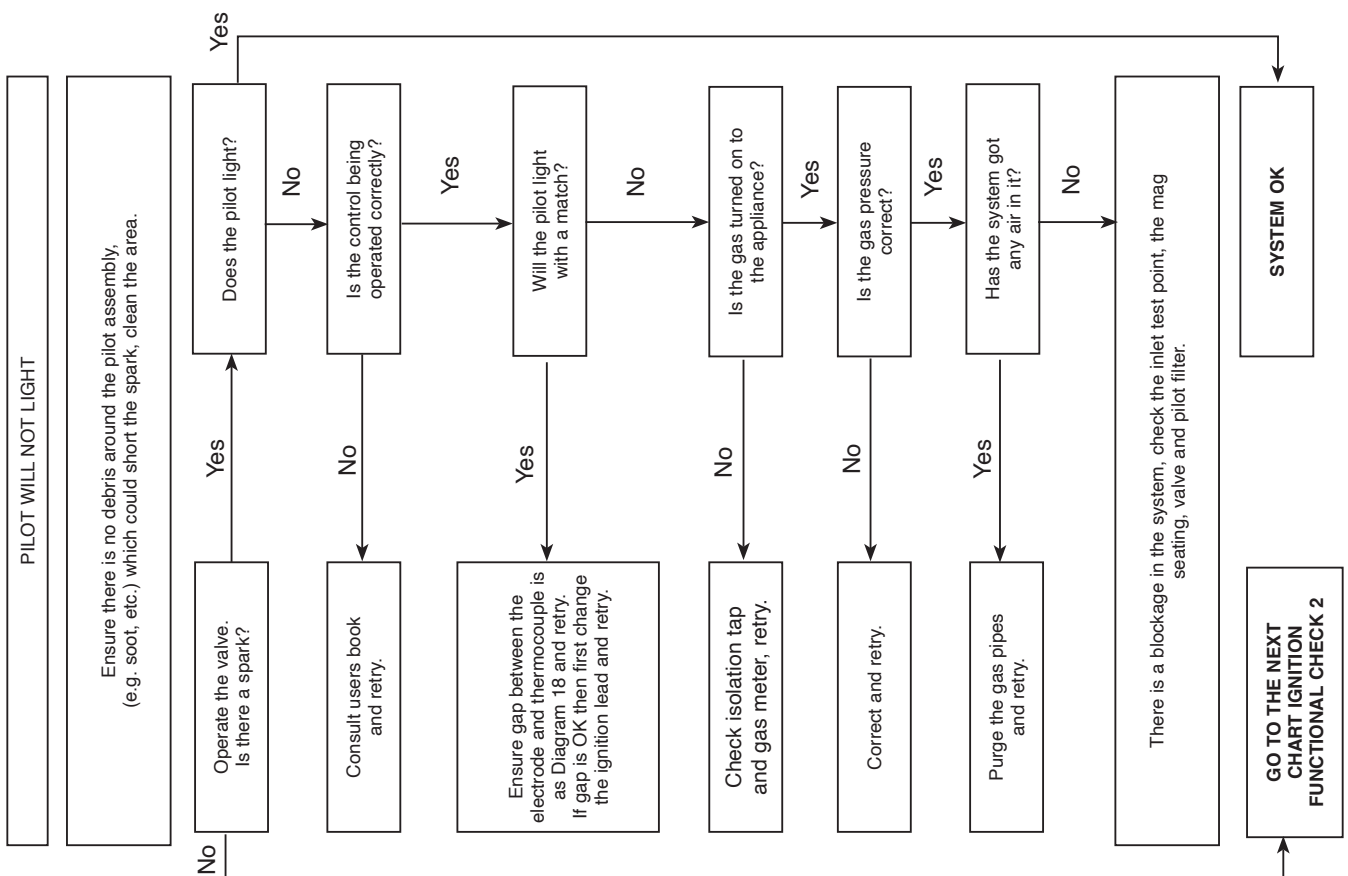

IGNITION FUNCTIONAL CHECK 2B - SLIDE CONTROL

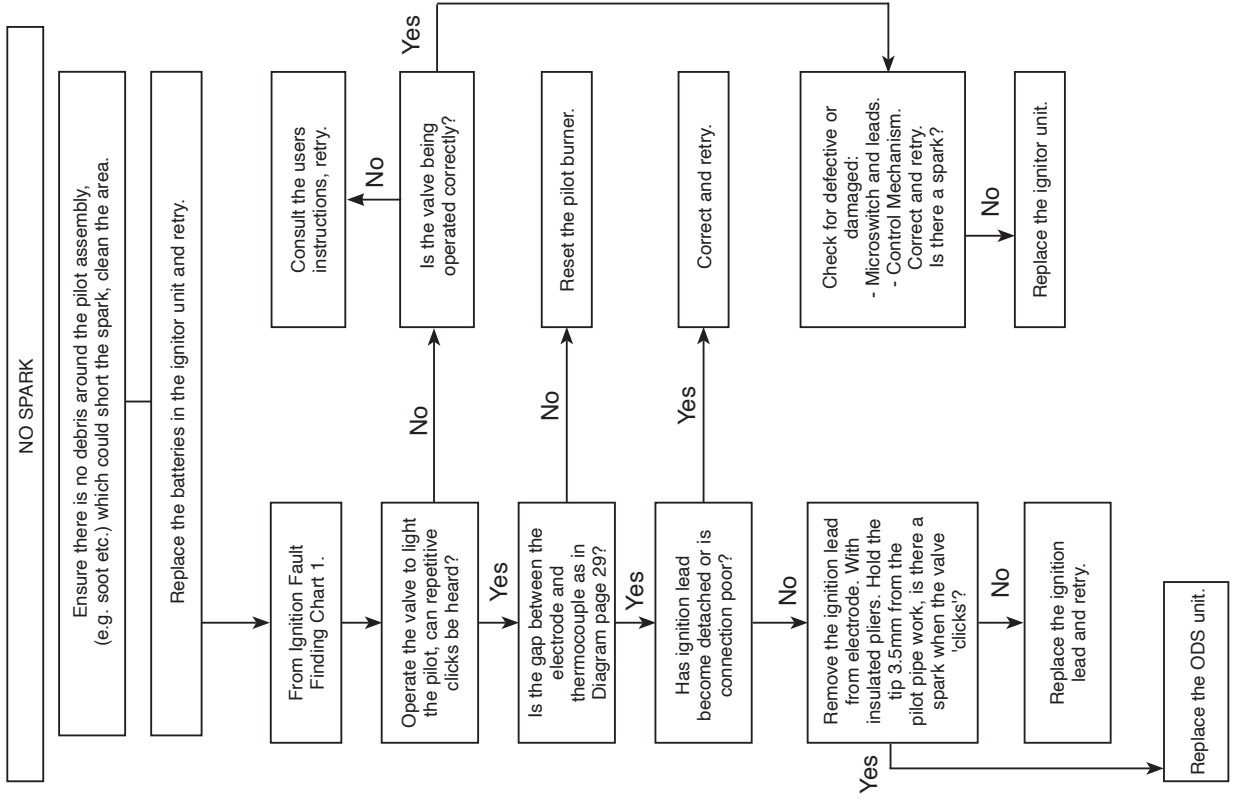

IGNITION FUNCTIONAL CHECK 2A MANUAL & REMOTE

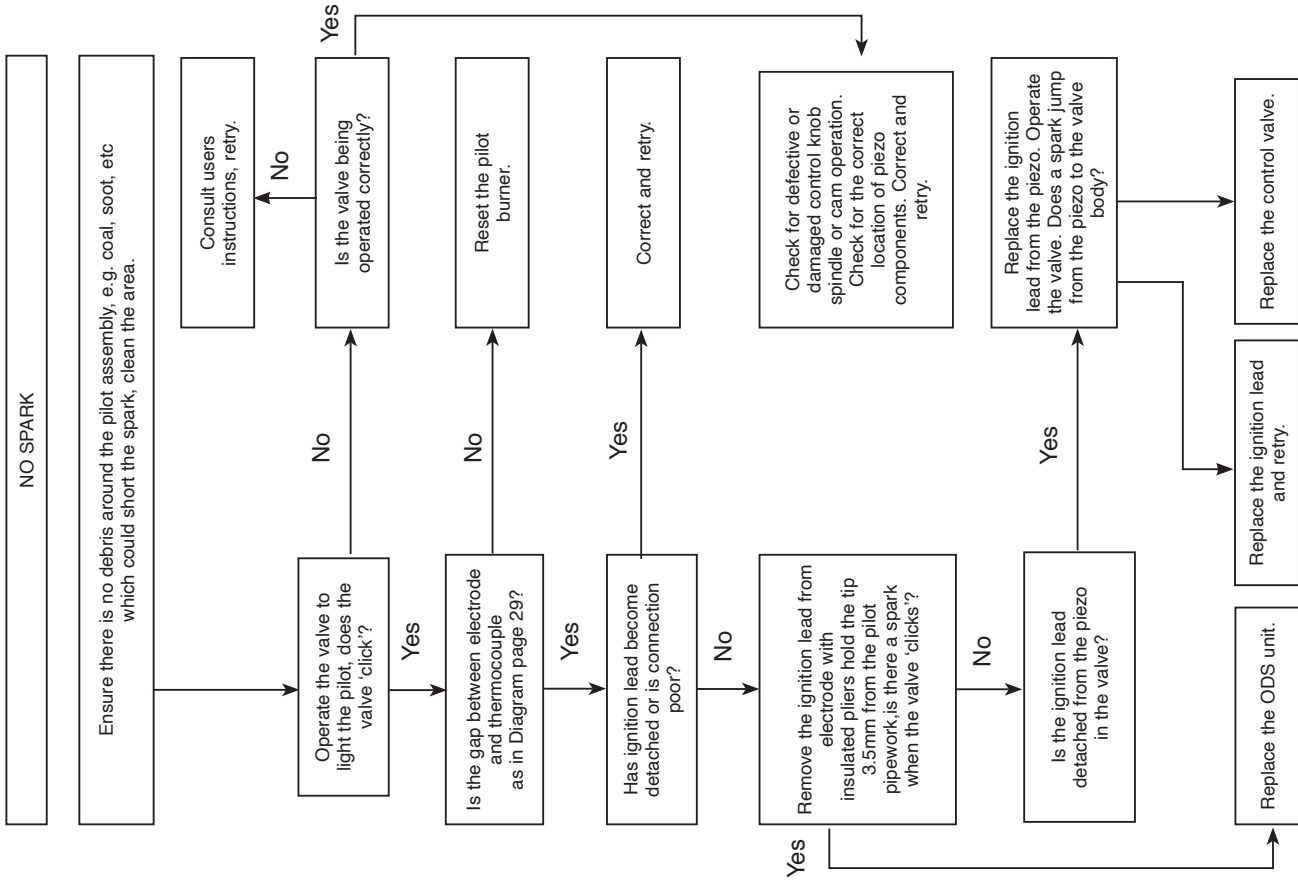

FLAME FAILURE FUNCTIONAL CHECK 3

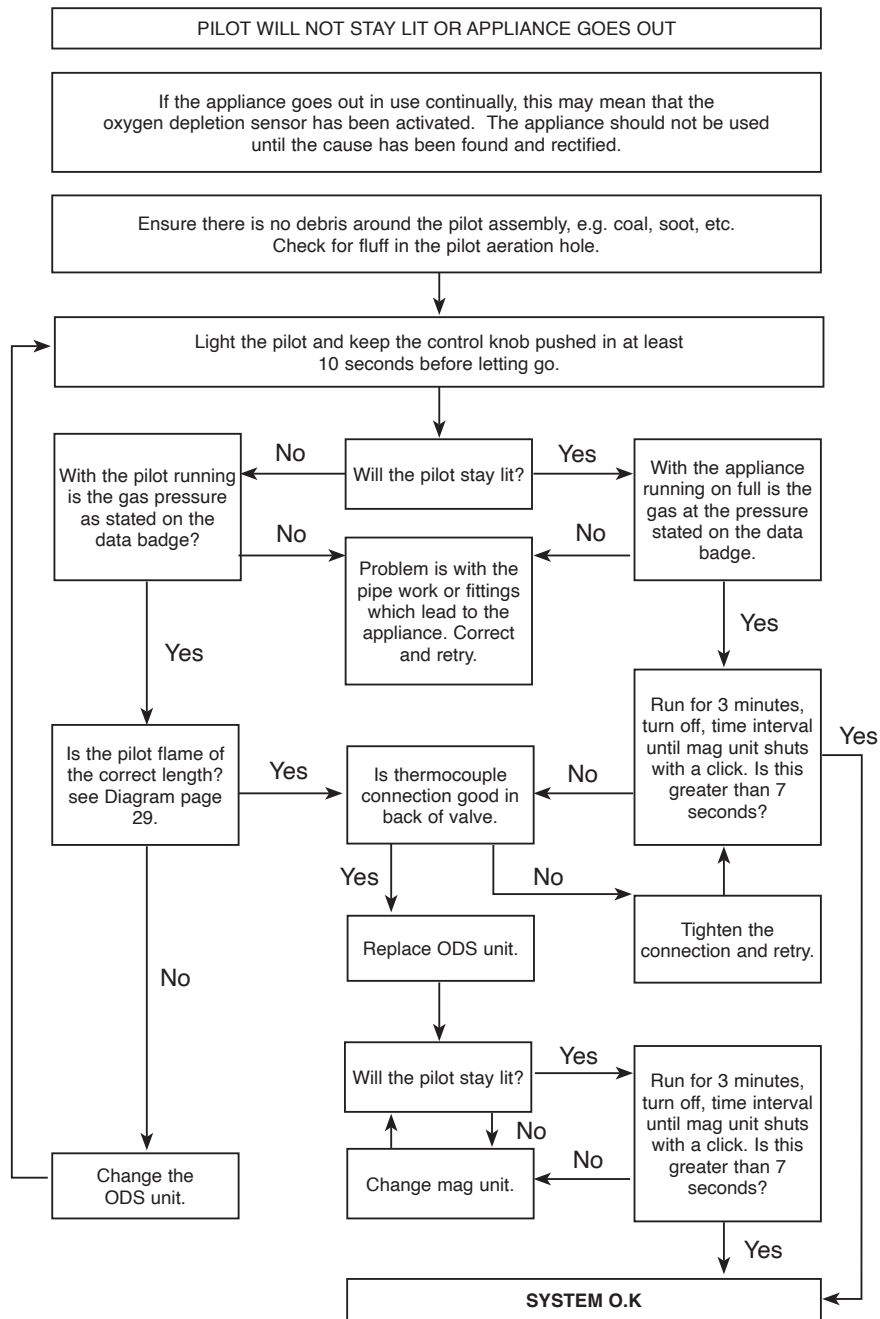

REPLACING PARTS

GENERAL

To service any of the following parts on the appliance, it will be necessary to remove the burner unit from the firebox. To remove the main burner proceed as follows.

Turn off the gas supply at the isolation device located under the appliance.

Disconnect the gas supply pipe leaving the isolation device on the supply pipe and not the appliance.

Remove the loose coals and place on a dry clean surface.

Remove the decorative front, fret and ash cover. There are 2 screws securing the front to the appliance. Refer to separate instructions.

Remove the front coal, flame baffle and all the ceramic liners. All these items are very fragile and need to be stored carefully.

MANUAL CONTROL

Remove the 5 screws securing the burner unit to the firebox.

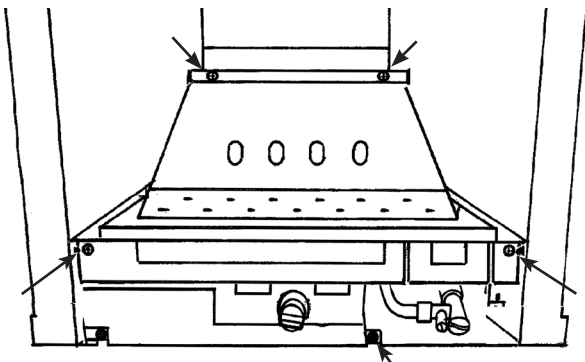

Clean any debris from the burner skin.

The burner unit can now be removed.

REMOTE CONTROL

Remove the 6 screws securing the burner unit to the firebox.

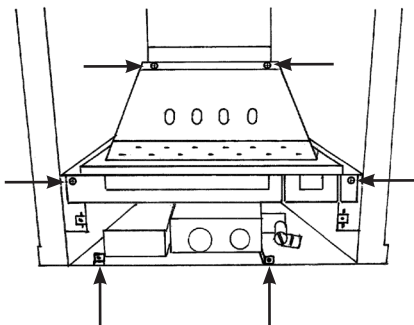

Clean any debris from the burner skin.

The burner unit can now be removed.

SLIDE CONTROL

Remove the battery before carrying out work on this appliance.

Removing the battery:

The battery box is located at the bottom left of the appliance behind the ash cover.

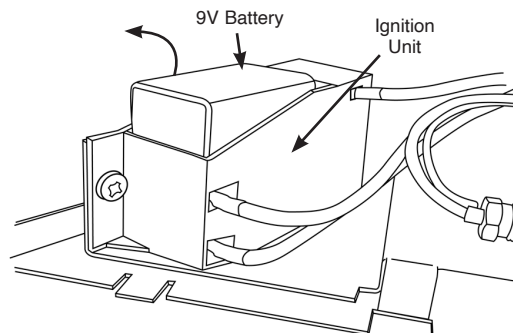

Remove the 2 screws securing the front baffle to the burner unit, Arrow A.

Ensure the baffle is replaced during re-assembly.

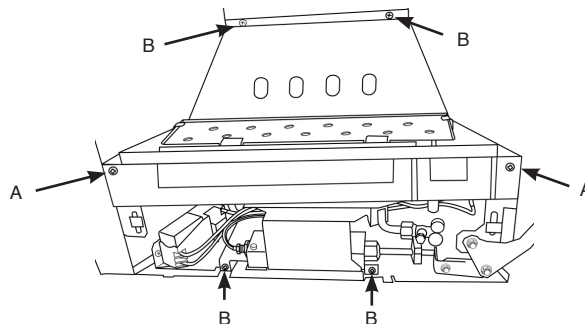

Remove the 4 screws securing the burner unit to the firebox, Arrow B.

Remove the M4 lock nut and spacer securing the slide arm to the appliance.

Ensure that the spacer is retained and replaced when the burner unit is reinstalled.

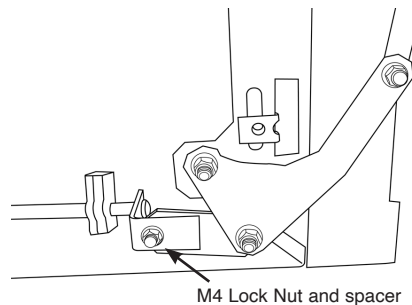

Clean any debris from the burner skin.

The burner unit can now be removed.

Take care not to catch the slide mechanism.

IGNITION LEAD

The different control versions of this appliance have different servicing requirements for the Ignition Lead. Follow the relevant section for each product.

MANUAL CONTROL

The Ignition lead and Piezo on this appliance are part of one complete unit and must be replaced at the same time.

To replace the unit remove the control knob on the front of the valve cover and undo the nut securing the valve.

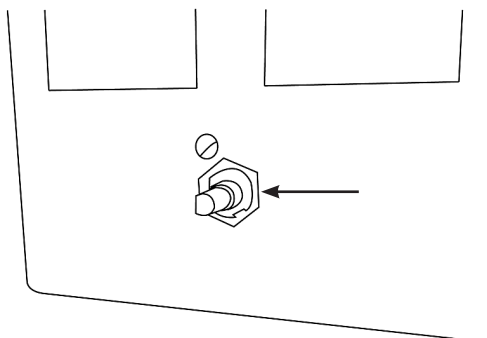

Disconnect all other valve connections on the rear of the valve.

The valve will now come off.

Remove the clip from around the front of the valve.

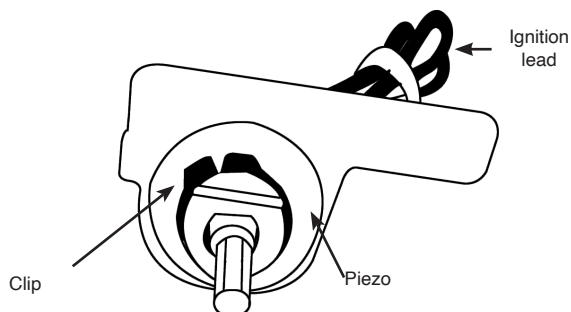

Rotate the Piezo anti-clockwise until the tab appears in the slot at the front.

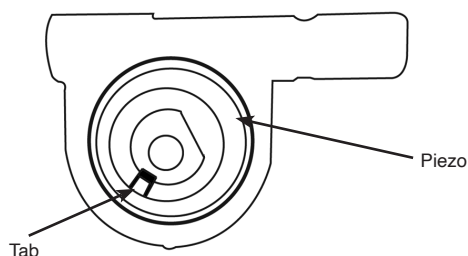

Withdraw the Piezo unit forward from the valve.

Replace with a new unit and re-assemble the valve into the burner unit.

Check the operation of the Piezo ignitor making sure that both ignition 'clicks' are functioning.

Reassemble the appliance.

REMOTE CONTROL

Undo the single screw that secures the left hand side of the control cover.

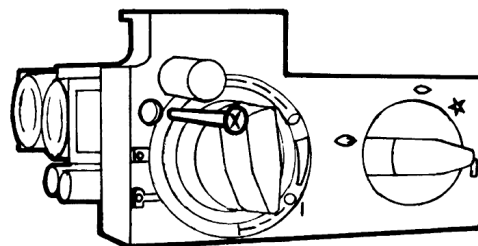

To release the right hand side of the control cover insert the narrow blade screwdriver into the slot shown in Diagram 10, lever it gently and pull from the right hand side at the same time. The cover will now come off, there is a small cylindrical metal spacer inside the cover, this must be kept and replaced on the fixing screw during re-assembly.

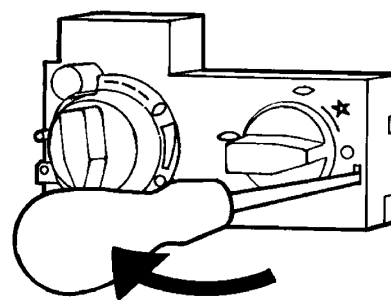

Disconnect the ignition lead from the gas valve and the pilot.

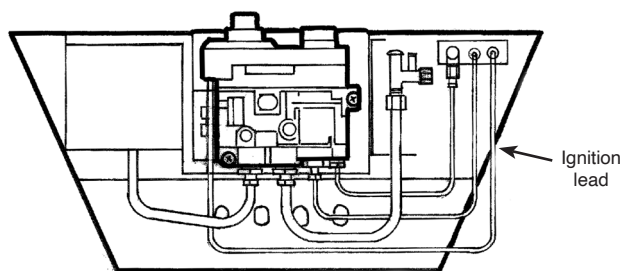

Replace with a new ignition lead following the same route as the old one. Replace the valve cover and the pilot assembly.

Refit the burner.

Check the operation of the new ignition lead.

Reassemble the appliance.

SLIDE CONTROL

Disconnect the ignition lead from the ignition unit and the pilot unit.

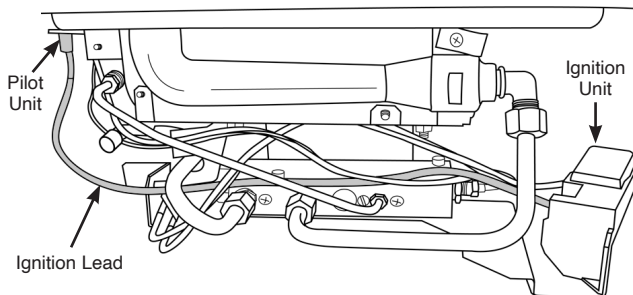

Replace with a new ignition lead following the same route as the old one.

Refit the burner.

Check the operation of the new ignition lead.

Reassemble the appliance.

PIEZO - MANUAL & REMOTE ONLY

Note: For the Manual Control Valve the Ignition lead and Piezo are part of one complete unit and must be replaced at the same time, see Section 2.

Remote Control Valve models:

The Piezo assembly used on this appliance is not serviceable and is unlikely to fail. If a new piezo is required it will be necessary to change the gas valve.

ODS PILOT UNIT



IMPORTANT: UNDER THE TERMS OF THE EXTENDED WARRANTY IT WILL BE COMPULSORY TO CHANGE THE COMPLETE PILOT UNIT ON THIS APPLIANCE IN YEARS 2, 4 AND 6.

Note: The pilot unit on the appliance is a non serviceable unit due to the complex nature of its manufacture.

Replacement of the complete unit must be carried out when one of the following items becomes faulty:

- Pilot injector
- Ignition electrode
- Thermocouple

Remove the burner.

Gently pull the ignition lead off the electrode, arrow A.

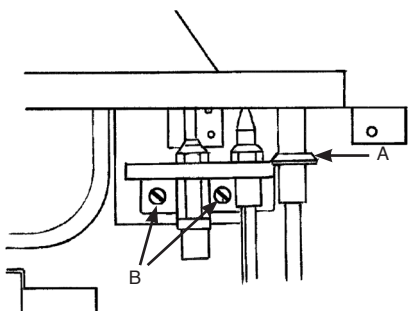

Remove the 2 screws securing the pilot assembly, see arrow B.

Follow the relevant instruction for your appliance.

MANUAL CONTROL & REMOTE CONTROL

Undo the thermocouple connection at the back of the gas valve and the pilot pipe at the pilot elbow, see arrows C and D.

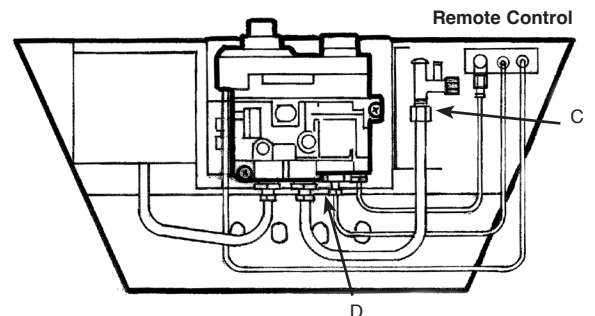
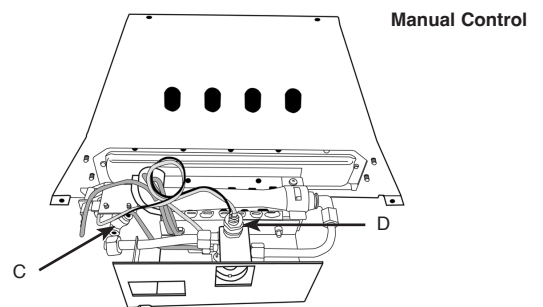

Replace the pilot assembly.

SLIDE CONTROL

Undo the thermocouple connection from the side of the gas valve.

Undo the pilot pipe from the pilot elbow and from the gas valve, Arrows E & F.

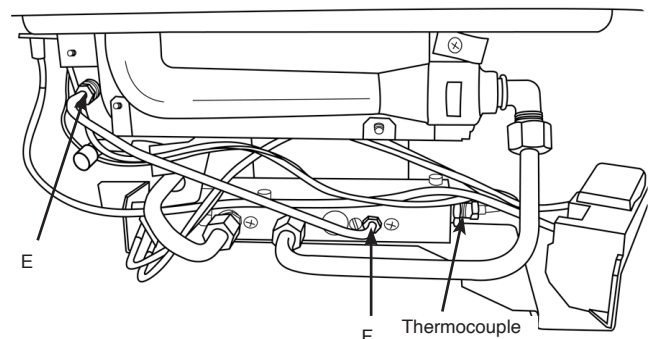

Replace the pilot assembly.

ALL MODELS

Replace with a new pilot assembly and check the spark gap.

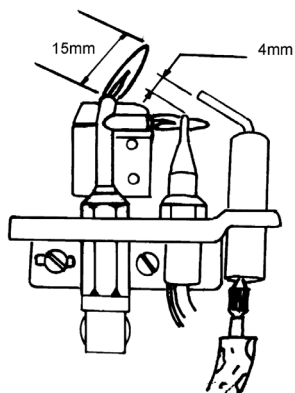

After reassembly, check for gas soundness and carry out a flame failure functional check details in the flow chart, especially the time it takes for the mag unit to close.

GAS VALVE

MANUAL CONTROL & REMOTE CONTROL

To remove the gas valve first remove the thermocouple, Arrow A.

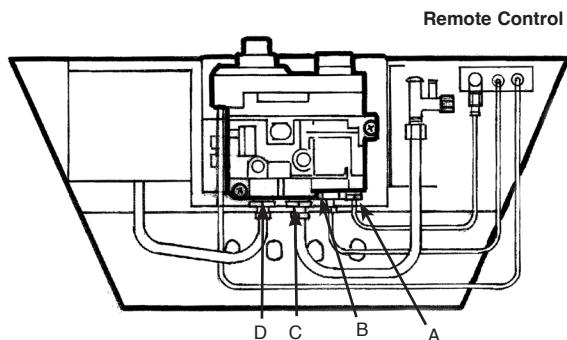
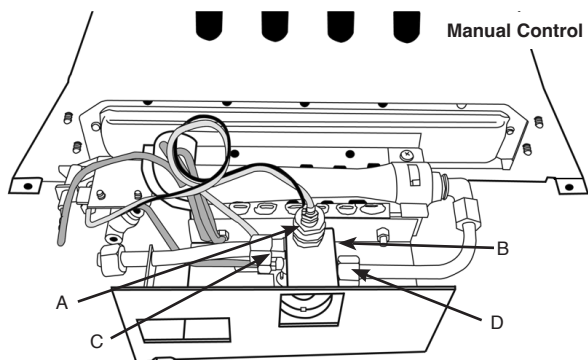

Undo the pilot pipe from the gas valve, Arrow B.

Undo the inlet pipe from the gas valve, Arrow C.

Undo the main injector feed pipe from the gas valve, Arrow D.

Disconnect the injector nut, Arrow E.

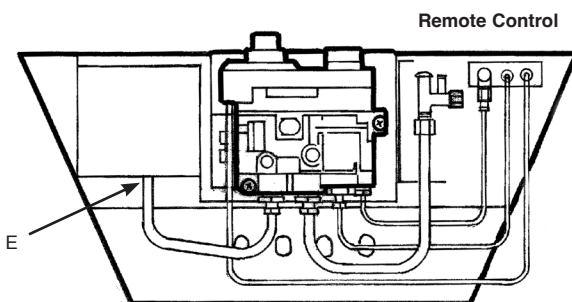
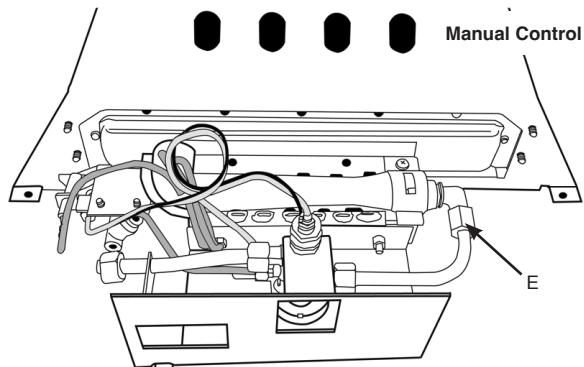

Undo the lock nut (Manual model) or 2 bolts (Remote model) securing the gas valve to the appliance and remove the valve.

Replace in reverse order.

Check all joints for gas leaks, check operation of the thermocouple and ignition lead.

SLIDE CONTROL

To remove the gas valve first remove the thermocouple, Arrow A.

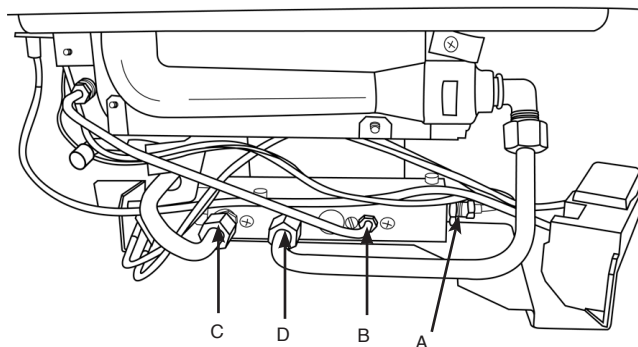

Undo the pilot pipe from the gas valve, Arrow B.

Undo the inlet pipe from the gas valve, Arrow C.

Undo the main injector feed pipe from the gas valve, Arrow D.

Disconnect the ignition lead from the pilot unit.

Disconnect the 2 leads from the micro-switch.

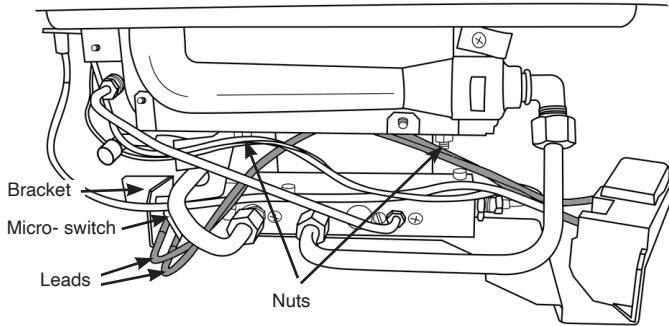

Undo the screw from the end of the spindle and remove the bracket. Ensure **the bracket is replaced during reassembly.**

Undo the 2 nuts securing the bracket to the bottom of the burner unit.

Undo the 2 screws securing the gas valve to the bracket.

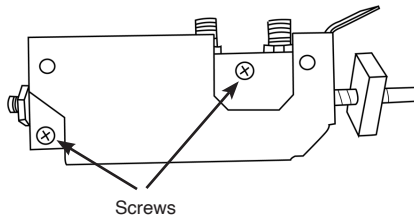

Replace in reverse order.

Check for gas leaks.

MAG UNIT

Undo the thermocouple nut, Arrow A.

Undo the mag unit retaining nut at the back of the control valve behind the thermocouple nut.

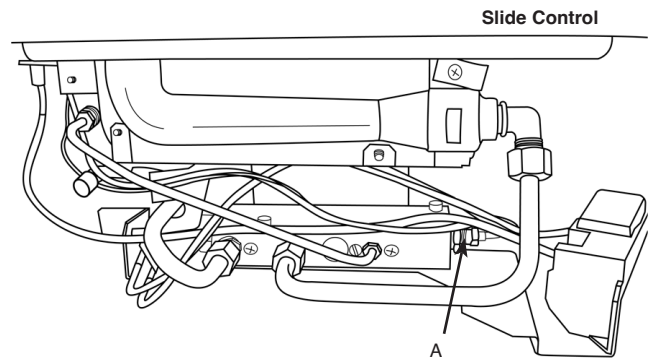
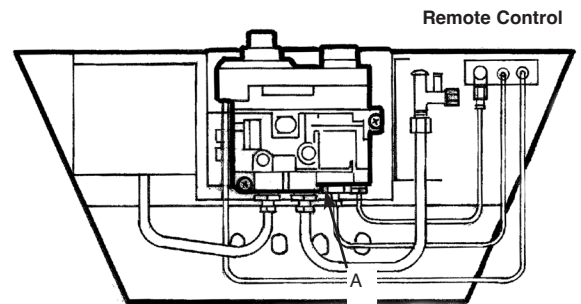
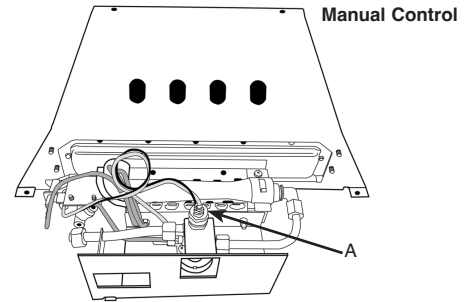

After removing the retaining nut, the mag unit can be tapped out and a replacement fitted.

Replace the mag unit retaining nut and tighten. Note - this is a gas-tight seal.

Replace the thermocouple and check for gas leaks.

After reassembly, carry out the flame failure functional check as detailed in the flow chart, especially the time it takes for the mag unit to close.

MAIN INJECTOR

Undo the injector compression nut and valve nut, see Arrows A and B, and pull the pipe clear of the injector body.

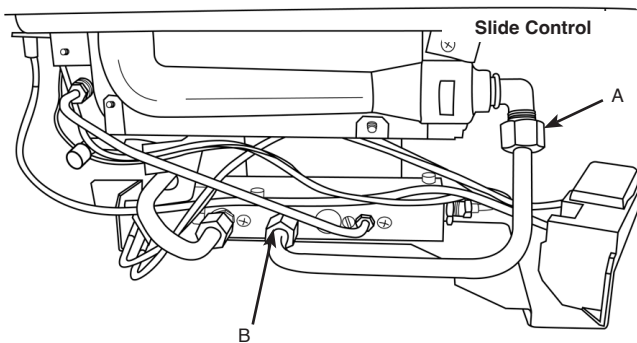
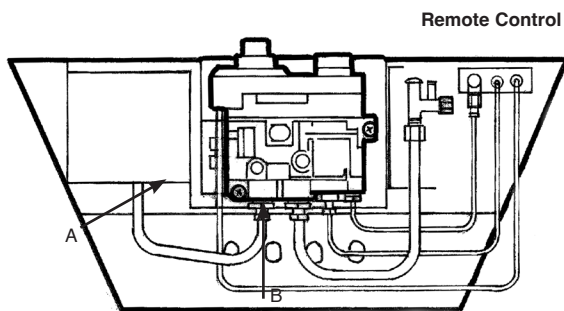
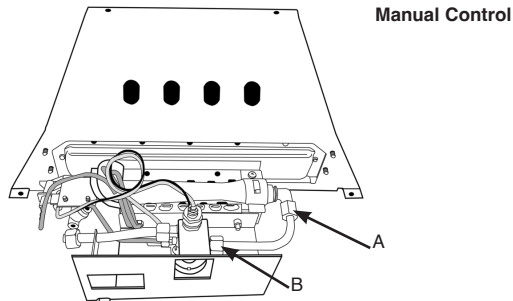

Rotate the injector until it is fully removed.

Replace with the correct replacement injector. When ordering, always state the model, gas type and serial number.

Reassemble and turn the gas supply on, check for any leaks.

IGNITION UNIT SLIDE CONTROL MODEL ONLY

Remove the battery.

Remove the 2 leads and the pilot ignition lead from the ignition unit.

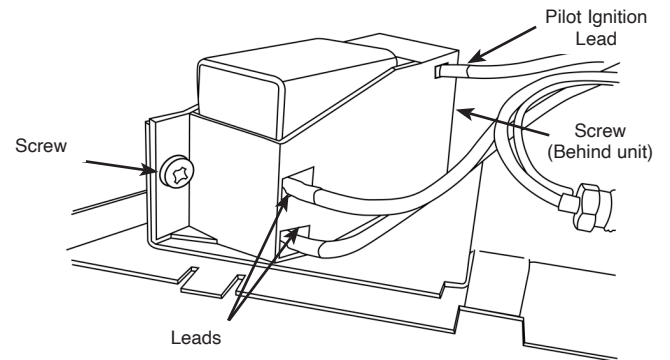

Undo the 2 screws securing the unit in place.

Replace in reverse order.

LOGIC CONVECTOR

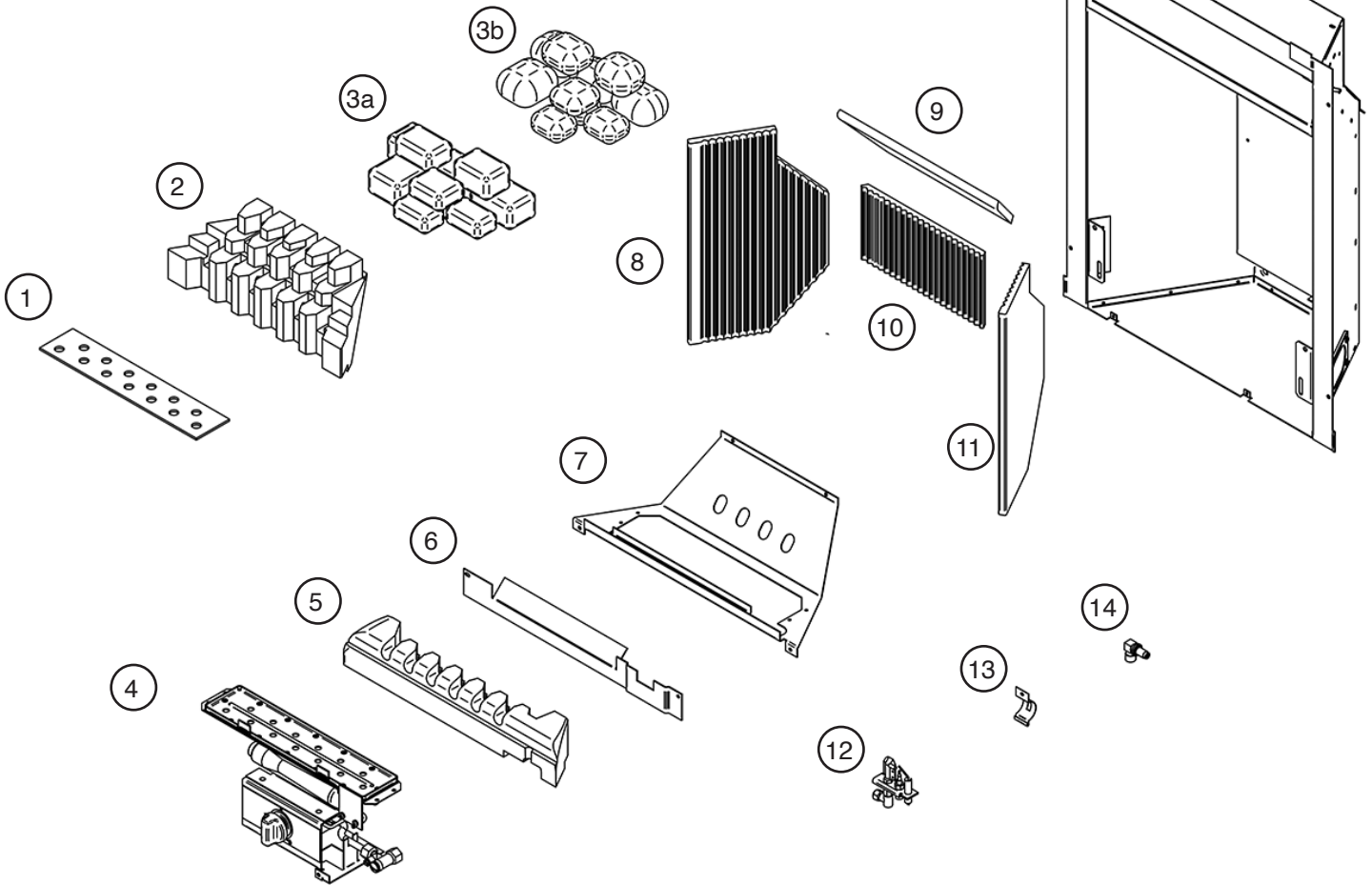

REF.	COMPONENT	COALS						QTY.
		MANUAL CONTROL		REMOTE CONTROL		SLIDE CONTROL		
		NG	LPG	NG	LPG	NG	LPG	
1	Burner Cover Gasket	CE0273						1
2	Flame Baffle	CE0402						1
3	Fuel Effect	a. CE0412						1
4	Burner Assembly	GZ8494	GZ8496	GZ8683	GZ8684	GZ8494	GZ8496	1
5	Front Coal	CE0400						1
6	Air Guide	GZ4038						1
7	Burner Tray	GZ4035						1
8	Ceramic Panel Left	CE0408						1
9	Ceramic Panel Top	CE0411						1
10	Ceramic Panel Back	CE0410						1
11	Ceramic Panel Right	CE0409						1
12	Oxypilot	PI0097	PI0098	PI0097	PI0098	PI0097	PI0098	1
13	Aeration Plate	GZ2016						1
14	Elbow Injector	IN0007 - size 400	IN0025 - size 180	IN0007 - size 400	IN0025 - size 180	IN0007 - size 400	IN0025 - size 180	1



Due to continual technical improvements please check online or with your Gazco retailer for the most up to date parts lists.

Only use Genuine Gazco spares when servicing your appliance.

All of our essential spare parts and consumable items are available to purchase from our webshop at www.gazcospares.com.

MANUAL CONTROL

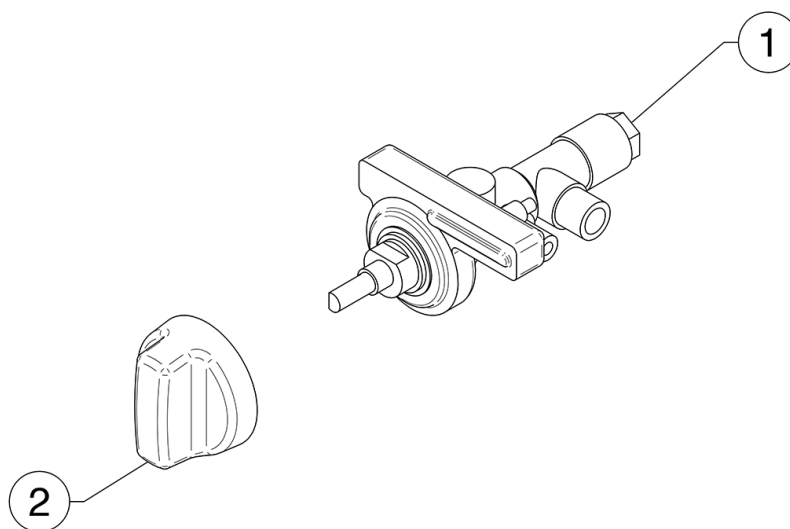

REF.	COMPONENT	PART CODE		QTY.
		NATURAL GAS	LPG	
1	Manual Control Valve	Yellow Spot GC0161	Blue Spot GC0162	1
2	Control Knob	GC0058		1



Due to continual technical improvements please check online or with your Gazco retailer for the most up to date parts lists.

Only use Genuine Gazco spares when servicing your appliance.
All of our essential spare parts and consumable items are available to purchase from our webshop at www.gazcospares.com.

REMOTE CONTROL



REF.	COMPONENT	PART CODE		QTY.
		NATURAL GAS	LPG	
1	Valve Kit	GC0088K		1
2	Control Cover	GC0087		1
3	Mag Unit	GC0166		1
4	Standard Remote Handset	EL0239		1
5+6	Standard Receiver and Cable	EL0647		1
6	Standard Receiver Cable Post 2016 Remote Kit - cable connection change for post 2016 receiver.	EL0237		1
	Standard Receiver Cable Pre 2016 Remote Kit - cable connection only suitable for Pre 2016 standard receiver.	EL0237A		
7	Geared Motor	EL0234		1
8	Ignition Lead	GC0090		1



Due to continual technical improvements please check online or with your Gazco retailer for the most up to date parts lists.

Only use Genuine Gazco spares when servicing your appliance.
All of our essential spare parts and consumable items are available to purchase from our webshop at www.gazcospares.com.

SLIDE CONTROL

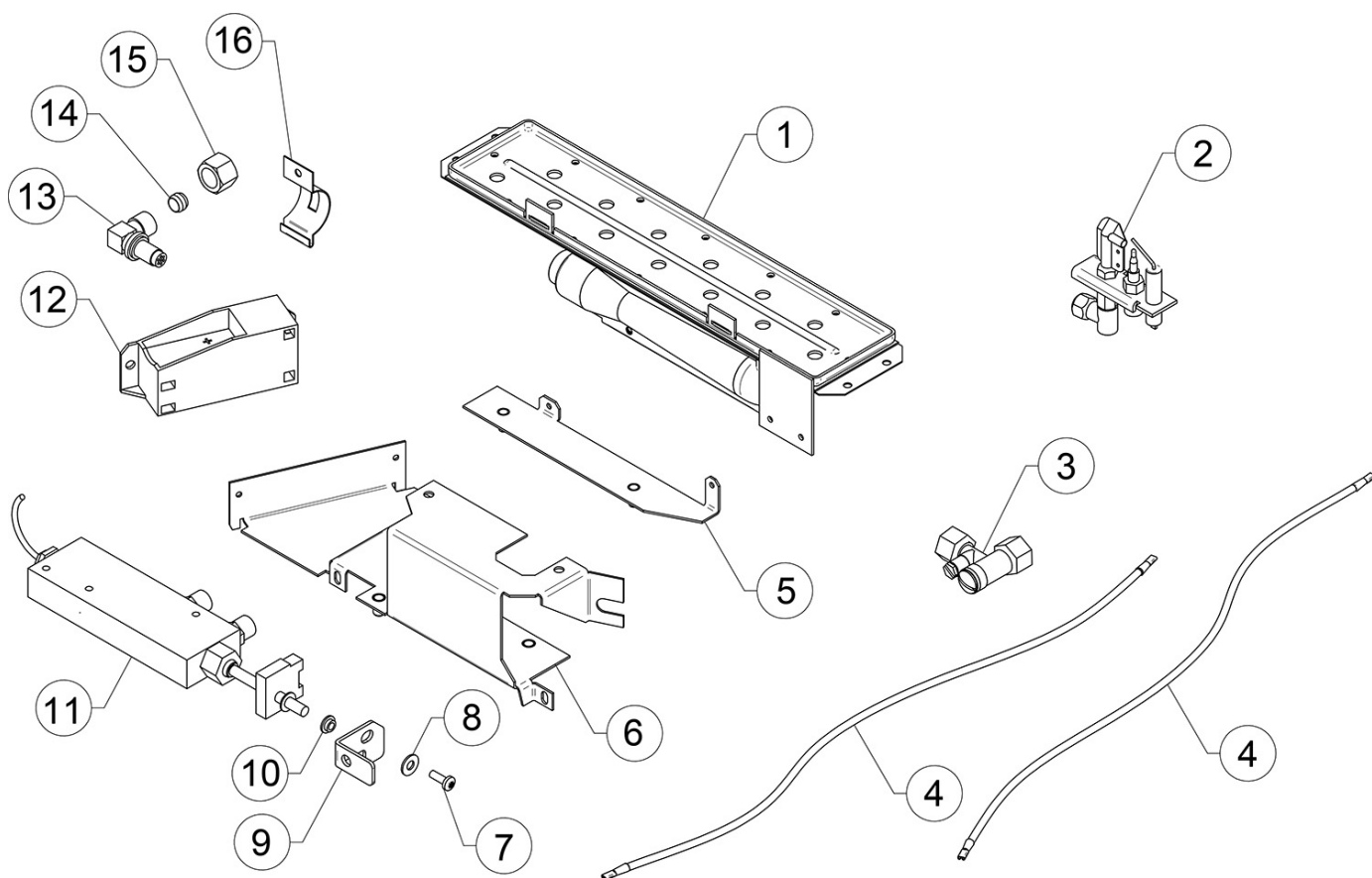

REF.	COMPONENT	PART CODE		QTY.
		NATURAL GAS	LPG	
1	Burner Assembly	GZ11636	GZ11635	1
2	Pilot	PI0097	PI0098	1
3	Restrictor Elbow	GC0095		1
4	Ignitor Lead	EL0578		3
5	Mounting Plate	GZ8788		1
6	Main Slide Control Bracket	GZ9521		1
7	M4 x 12mm Screw	D2150-1412		1
8	Washer	FA0705		1
9	Slider Valve Actuator Bracket	GZ11007		1
10	Clearance Spacer	FA0685		1
11	Slider Control Valve	GC0168		1
12	Ignitor	EL0573		1
13	Injector	IN0007	IN0025	1
14	Olive	FA0011		1
15	Nut	FA0029		1
16	Aeration Cover	GZ2016		1

(EU) 2024/1103 Ecodesign Regulation

TABLE 1: INFORMATION REQUIREMENTS FOR GASEOUS FUEL LOCAL SPACE HEATERS

	Model Identifier(s):		101-295	101-418	101-349	101-528	101-053	101-796	
	Indirect heating functionality:		No	No	No	No	No	No	
	Direct heat output:		4.1	4.2	4.1	4.2	4.1	4.2	kW
	Indirect heat output:		N.A.	N.A.	N.A.	N.A.	N.A.	N.A.	
	Minimum permissible total flue duct length (vertical + horizontal pipe):		3.0	3.0	3.0	3.0	3.0	3.0	m
Symbol									Unit
Fuel	Select fuel type:		Gaseous						
	Nitrogen oxides (NOx) emission		120	120	120	120	120	120	mg/kWh input (GCV)
Heat Output	Nominal Heat Output	P_{nom}	4.1	4.2	4.1	4.2	4.1	4.2	kW
	Minimum Heat Output (indicative)	P_{min}	1.6	1.6	1.6	1.6	1.6	1.6	kW
Useful Efficiency (NCV)	Useful Efficiency at nominal heat output	$\eta_{th,nom}$	68.5	68.5	68.5	68.5	68.5	68.5	%
	Useful Efficiency at minimum heat output (indicative)	$\eta_{th,min}$	58.5	58.5	58.5	58.5	58.5	58.5	%
	Seasonal space heating energy efficiency	η_s	51.8	51.9	51.8	51.9	53.1	53.1	%
Auxiliary Electricity Consumption	At Nominal Heat Output	e_{max}	0.000	0.000	0.000	0.000	0.000	0.000	kW
	At Minimum Heat Output	e_{min}	0.000	0.000	0.000	0.000	0.000	0.000	kW
Power consumption	In off mode	P_0	0.00	0.00	0.00	0.00	0.00	0.00	kW
	In standby mode	P_{sm}	0.00	0.00	0.00	0.00	0.00	0.00	kW
	In idle mode	P_{idle}	0.00	0.00	0.00	0.00	0.00	0.00	kW
	In networked standby mode	P_{nsm}	0.00	0.00	0.00	0.00	0.00	0.00	kW
	Standby mode with display of information or status		No	No	No	No	No	No	
Permanent Pilot Flame Power consumption (if applicable)	P_{pilot}		0.2	0.2	0.2	0.2	N.A.	N.A.	kW
Type of heat output/room temperature control (select one)			TX	TX	TX	TX	TX	TX	
Key:	NC: single stage heat output, no room temperature control TX: two or more manual stages, no temperature control TM: with mechanic thermostat room temperature control		TE: with electronic room temperature control TD: with electronic room temperature control plus day timer TW: with electronic room temperature control plus week timer						
Other control options (multiple selections possible)									
Room temperature control, with presence detection									No
Room temperature control, with open window detection									No
With distance control option									No
With adaptive start control									No
With working time limitation									No
With black bulb sensor									No

REGULATION (EU) 2015/1186 ENERGY LABELLING – LOCAL SPACE HEATERS PRODUCT FICHE

(a) supplier's name or trademark:	Stovax Gazco Ltd.					
	Logic Convector Manual NG	Logic Convector Manual LPG	Logic Convector Remote NG	Logic Convector Remote LPG	Logic Convector Slide NG	Logic Convector Slide LPG
(b) supplier's model identifier:	101-295	101-418	101-349	101-528	101-053	101-796
(c) the energy efficiency class of the model:	F	F	F	F	F	F
(d) the direct heat output in kW:	4.1	4.2	4.1	4.2	4.1	4.2
(e) the indirect heat output in kW:	N.A.	N.A.	N.A.	N.A.	N.A.	N.A.
(f) the energy efficiency index	57	57	57	57	60	60
(g) the useful energy efficiency at: nominal heat output: and at minimum load:	68.5 58.5	68.5 58.5	68.5 58.5	68.5 58.5	68.5 58.5	68.5 58.5
(h) any specific precautions that shall be taken when the local space heater is assembled, installed or maintained	None	None	None	None	None	None

PRODUCT MATERIAL INFORMATION

The following substances, preparations or components should be disposed of or recovered separately from other WEEE in compliance with Article 4 of EU Council Directive 75/442/EEC.

Metal	Steel	Can be taken to a local recycling centre for reuse to reduce waste going to landfill.
	Cast iron	
Glass		Can be taken to a local recycling centre for reuse to reduce waste going to landfill.
Rope seals/ Coal Fuel Effects and Black Reed Liners		These items are made from Refractory Ceramic Fibre (RCF), a material which is commonly used for this application. Protective clothing is not required when handling these articles, but it is recommended to follow normal hygiene rules of not smoking, eating or drinking in the work area and always wash hands before eating or drinking. When servicing the appliance it is recommended that the replaced items are not broken up, but are sealed within heavy duty polythene bags and labelled as RCF waste. RCF waste is classed as stable, non-reactive hazardous waste and may be disposed of at a licensed landfill site.
Electrical components	(Fan kits, etc. if applicable)	Dispose of at a local recycling centre in accordance with the WEEE directive.

SERVICE RECORDS

1ST SERVICE

Date of Service
Next Service Due
Signed
Retailer's Stamp/GasSafe Registration Number

2ND SERVICE

Date of Service
Next Service Due
Signed
Retailer's Stamp/GasSafe Registration Number

3RD SERVICE

Date of Service
Next Service Due
Signed
Retailer's Stamp/GasSafe Registration Number

4TH SERVICE

Date of Service
Next Service Due
Signed
Retailer's Stamp/GasSafe Registration Number

5TH SERVICE

Date of Service
Next Service Due
Signed
Retailer's Stamp/GasSafe Registration Number

6TH SERVICE

Date of Service
Next Service Due
Signed
Retailer's Stamp/GasSafe Registration Number

7TH SERVICE

Date of Service
Next Service Due
Signed
Retailer's Stamp/GasSafe Registration Number

8TH SERVICE

Date of Service
Next Due
Signed
Retailer's Stamp/GasSafe Registration Number

9TH SERVICE

Date of Service
Next Service Due
Signed
Retailer's Stamp/GasSafe Registration Number

10TH SERVICE

Date of Service
Next Service Due
Signed
Retailer's Stamp/GasSafe Registration Number

FOR ENQUIRIES IN THE U.K (EXCLUDING NI):

Stovax Gazco Ltd, Spitfire Avenue, Skypark, Clyst Honiton, Exeter, Devon, England EX5 2FR

Tel: (01392) 474011 E-mail: info@stovax.com www.stovax.com

FOR ENQUIRIES IN EUROPE (INCLUDING NI):

Stovax Heating Group (NI) Ltd (Comp reg NI675194), 40 Linenhall Street, Belfast, BT2 8BA

DX 400 NR Belfast Tel: +44 (0)1392 261990 E-mail: northernireland@stovax.com

